

TOSHIBA

Leading Innovation >>>

GR Series Relay

N u m e r i c a l R e l a y

GRD110

NUMERICAL
OVERCURRENT
PROTECTION



GRD110

FEATURES

- Overcurrent protection for phase and earth faults with IDMTL or DTL.
- Three instantaneous elements with DTL.
- Programmable reset characteristics.
- Sensitive earth fault protection (SEF).
- Restricted earth fault protection
- Undercurrent protection with DTL.
- Thermal overload protection.
- Negative phase sequence overcurrent protection (NPS).
- Broken conductor detection.
- Circuit breaker fail protection.
- Inrush current detector for blocking differential and/or overcurrent trip at energisation.
- Cold load pick-up feature.
- Five shot, three phase auto-reclose (six trips to lockout).
- Sequence co-ordination with in-series auto-reclosing devices.
- Four settings groups.
- Configurable binary inputs and outputs.
- Circuit breaker condition monitoring.
- Trip circuit supervision.
- Automatic self-supervision.
- Menu-based HMI system.
- Configurable LED indication.
- Metering and recording functions.
- Communication for remote setting and data download is provided via the RSM (Relay Setting and Monitoring) system.
- Front mounted RS232 serial port for local PC communications.
- Rear mounted RS485 or fibre optic serial port for remote PC communications.
- The IEC60870-5-103 protocol is provided for communication with substation control and automation systems.

APPLICATION

The GRD110 is a range of fully numeric multi-function protection relays. GRD110 has five models which differ according to the number and type of current inputs fitted, see Table 1.

Table 1 - GRD110 Models

Model	Configuration
GRD110-110	Earth Fault and Sensitive Earth Fault
GRD110-400	Three Phase Fault and Earth Fault
GRD110-420	Three Phase Fault, Earth Fault and Sensitive Earth Fault
GRD110-500	Three Phase Fault and Earth Fault and Auto-reclose
GRD110-520	Three Phase Fault, Earth Fault, Sensitive Earth Fault, and Auto-reclose

All models include multiple, high accuracy, overcurrent protection elements (for phase and/or earth fault) with inverse time and definite time delay functions. Other protection functions are available according to model type, including phase undercurrent protection with definite time delay, thermal protection to IEC60255-8, negative sequence overcurrent protection and a broken conductor detection feature, see Table 2.

All models provide continuous monitoring of internal circuits and of software. External circuits are also monitored, by trip circuit supervision and CB condition monitoring features.

A user-friendly HMI is provided through a backlit LCD, programmable LEDs, keypad and menu-based operating system. PC access is also provided, either for local connection via a front-mounted RS232 port, or for remote connection via a rear-mounted RS485 or fibre optic port. The communication system allows the user to read and modify the relay settings, and to access data gathered by the relay's metering and recording functions.

Data available either via the relay HMI or communications ports includes the following functions.

- Metering
- Fault recording
- Event recording
- Disturbance recording (available via communications ports)

GRD110

Table 2 - GRD110 Features

Model Number	GRD110 -				
	110	400	420	500	520
Phase Fault O/C (50/51P)		✓	✓	✓	✓
Earth Fault O/C (50/51N)	✓	✓	✓	✓	✓
SEF (50/51N)	✓		✓		✓
Phase Undercurrent (37P)		✓	✓	✓	✓
Thermal Overload (49)		✓	✓	✓	✓
NPS Overcurrent (46)		✓	✓	✓	✓
Broken Conductor		✓	✓	✓	✓
Circuit Breaker Fail (50BF)		✓	✓	✓	✓
Inrush current detector				✓	✓
Cold Load Protection		✓	✓	✓	✓
Auto-reclose (79)				✓	✓
Trip circuit supervision	✓	✓	✓	✓	✓
Self supervision	✓	✓	✓	✓	✓
CB State Monitoring	✓	✓	✓	✓	✓
Trip Counter Alarm	✓	✓	✓	✓	✓
ΣI^2 Alarm		✓	✓	✓	✓
CB Operate Time Alarm	✓	✓	✓	✓	✓
Four settings groups	✓	✓	✓	✓	✓
Metering	✓	✓	✓	✓	✓
Fault records	✓	✓	✓	✓	✓
Event records	✓	✓	✓	✓	✓
Disturbance records	✓	✓	✓	✓	✓
IEC60870-5-103 Communication	✓	✓	✓	✓	✓

PROTECTION FUNCTIONS

Phase Fault Overcurrent Protection

Models GRD110-400, 420, 500 and -520 can provide two or three phase overcurrent protection. Each provides four independent overcurrent thresholds. The first and second thresholds may be set for inverse time or definite time operation. If inverse time is selected, then any one of nine curves may be chosen, including IEC and IEEE/ ANSI standard characteristics. Further, user configurable curve is available, if required. See Figure 1.

The first and second thresholds have a programmable reset feature, selectable for instantaneous, definite time or dependent time reset. This feature can be used to protect against flashing fault conditions, or to grade correctly with electromechanical overcurrent relays.

The other overcurrent thresholds may be set for definite time, or instantaneous operation. These elements are immune to the effects of transformer magnetising inrush and dc offset transient over-reach.

All elements can be inhibited by binary input signals for operation in blocked overcurrent schemes and busbar zone blocking protection.

Earth Fault Protection

The standard earth fault protection is available in all models, and provides four independent overcurrent thresholds. Protection functionality is the same as for the phase fault elements, only with more sensitive current thresholds.

For models GRD110-110, 400 and -500 the earth fault quantity is measured directly, either by connecting the input in the residual circuit of the phase CTs, or, as is recommended for more sensitive settings, using a dedicated core balance earth fault CT. For model GRD110-420 and -520, the standard earth fault quantity is derived internally from the residual sum of the three phases.

Sensitive Earth Fault Protection (SEF)

GRD110-110, 420 and -520 provide earth fault protection with more sensitive settings for use in applications where the fault current magnitude may be very low. A 2-stage overcurrent function is provided, with the first stage programmable for inverse time or definite time operation. The second stage provides definite time operation and runs after operation of the first stage. Three additional overcurrent thresholds are provided, each with a definite time delay.

The sensitive earth fault element includes a digital filter which rejects all harmonics other than the fundamental power system frequency.

The sensitive earth fault quantity is measured directly,

using a dedicated core balance earth fault CT.

This input can also be used in transformer restricted earth fault applications, by the use of external metrosils and setting resistors.

Phase Undercurrent Protection

Protection against loss of load is provided by the phase undercurrent protection. Two independent thresholds are provided, each with a programmable definite time delay.

Thermal Overload Protection

The thermal overload feature provides protection for cables and other plant against the effects of prolonged operation under excess load conditions. A thermal replica algorithm is applied to create a model for the thermal characteristics of the protected plant. Tripping times depend not only on the level of overload current, but also on the level of prior load current, the thermal replica providing 'memory' of previous conditions.

The thermal characteristics of the system are defined by entering settings for full load current and thermal time constant. The GRD110 issues a trip according to the 'cold' and 'hot' curves specified in IEC60255-8 (see Figure 2), to prevent the protected system from exceeding its thermal capacity. The cold curve tripping times are applicable when the system is first energised, while the hot curves are relevant when the system has already been carrying some prior load for a period of time. An alarm output is also available to give early warning of high load current, set as a percentage of thermal capacity.

Negative Phase Sequence Overcurrent Protection (NPS)

NPS protection can be used in applications where certain fault conditions may not be detected by the normal phase and earth overcurrent protections, for example, in the case of a relay applied on the delta side of a delta-star transformer, to detect an earth fault on the star side. Alternatively, NPS can be used to protect a three phase motor against the severe overheating which results from operating with an unbalanced supply.

Two independent thresholds are provided, each with a programmable definite time delay.

Broken Conductor Protection

The unbalance condition caused by an open circuited conductor is detected by the broken conductor protection. An unbalance threshold with programmable definite time delay is provided.

Circuit Breaker Fail Protection (CBF)

Two stage CBF protection provides outputs for re-tripping of the local circuit breaker and/or back-tripping to upstream circuit breakers. The CBF

GRD110

functions can also be initiated by external protections via a binary input if required.

Inrush Current Detector

GRD110-500 and -520 provides an inrush current detector against magnetizing inrush currents during transformer energisation. The inrush current detector detects the ratio between second harmonic current and fundamental current.

Cold Load Protection

The cold load function modifies the overcurrent protection settings for a period after energising the system. This feature is used to prevent unwanted protection operation when closing on to the type of load which takes a high level of current for a period after energisation. This is achieved by a 'Cold Load Settings Group' in which the user can programme alternative settings. Normally the user will choose higher current settings and/or longer time delays and/or disable elements altogether within this group.

Auto-Reclose

GRD110-500 and -520 provides an auto-reclose function. Four independent sequences are provided, one for each of the following:

Phase fault

Earth fault

Sensitive earth fault

External trip (initiated by a binary input)

Each sequence is independently programmable for single shot, two shot, three shot, four shot or five shot (i.e. six trips to lock-out) auto-reclose. Each protection trip is programmable for instantaneous or delayed operation, and each ARC shot has a programmable dead time. Sequence co-ordination is maintained between the auto-reclose sequences of in-series relays on a feeder.

Inverse Time Operate and Reset Curves

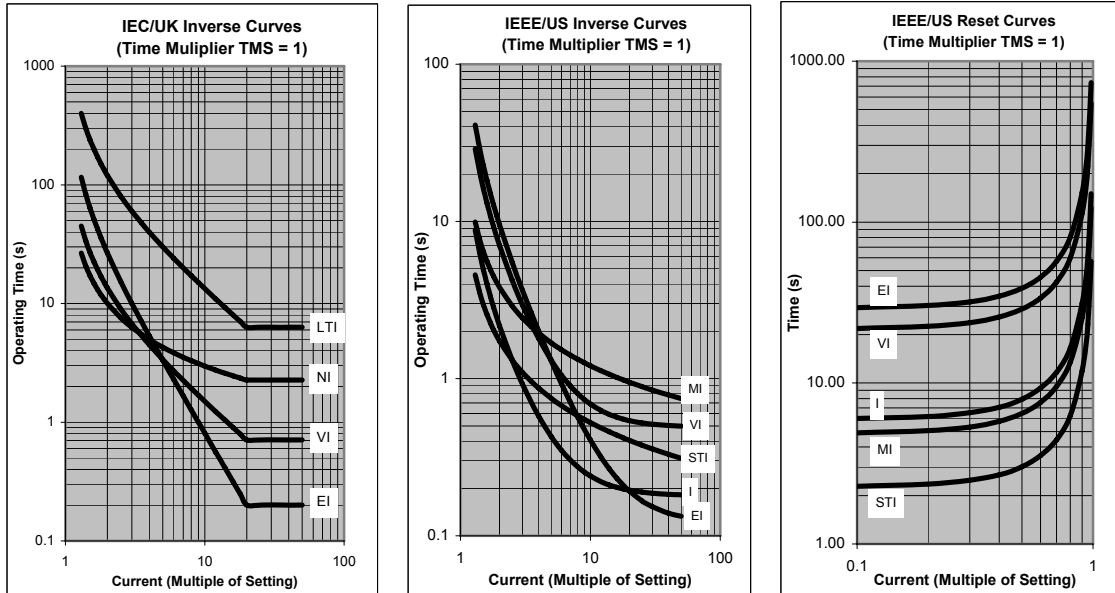

$$t = TMS \times \left\{ \left[\frac{k}{\left(\frac{I}{I_s} \right)^\alpha - 1} \right] + c \right\}$$

Inverse time operate function

$$t_{do} = \left[\frac{kr}{1 - \left(\frac{I}{I_s} \right)^\beta} \right] \times RTMS$$

Dependent time reset function

Constants for dependent time curves

Curve Description	k	α	C	k_r	β
IEC Normal Inverse (NI)	0.14	0.02	0	-	-
IEC Very Inverse (VI)	13.5	1	0	-	-
IEC Extremely Inverse (EI)	80	2	0	-	-
UK Long Time Inverse (LTI)	120	1	0	-	-
IEEE Moderately Inverse (MI)	0.0515	0.02	0.114	4.85	2
IEEE Very Inverse (VI)	19.61	2	0.491	21.6	2
IEEE Extremely Inverse (EI)	28.2	2	0.1217	29.1	2
US CO8 Inverse (I)	5.95	2	0.18	5.95	2
US CO2 Short Time Inverse (STI)	0.02394	0.02	0.01694	2.261	2
User configurable setting	0.00 – 30.000	0.00 – 5.00	0.000 – 5.000	0.000 – 30.000	0.00 – 5.00

Figure 1 - Operate and Reset Characteristics

IEC60255-8 Thermal Characteristics

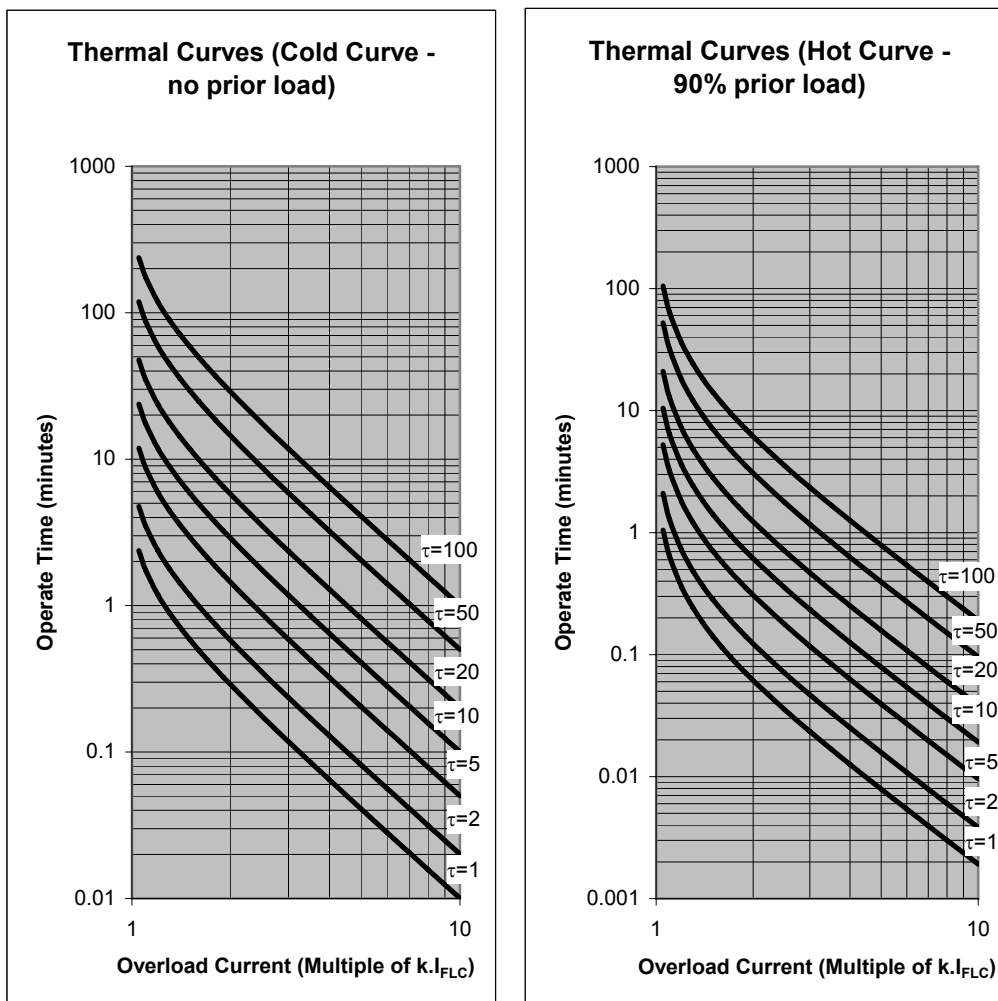

$$t = \tau \cdot \text{Ln} \left[\frac{I^2}{I^2 - (k \cdot I_{FLC})^2} \right];$$

IEC60255-8 'Cold' Curve

- t = time to trip for constant overload current I (seconds)
- I = overload current (largest phase current) (pu)
- I_p = previous load current (pu)
- k.I_{FLC} (or I₀) = thermal overload current setting (pu)
- τ = thermal time constant (seconds)
- Ln = natural logarithm

$$t = \tau \cdot \text{Ln} \left[\frac{I^2 - I_p^2}{I^2 - (k \cdot I_{FLC})^2} \right];$$

IEC60255-8 'Hot' Curve

Figure 2 - IEC60255-8 Thermal Characteristics

GRD110

Date and Time

GRD110 provides a date and time feature for tagging of records.

USER INTERFACE

Relay Front Panel

A user friendly interface is provided on the relay front panel. A menu-based system provides for easy programming of relay functions and access to real-time and stored data. The front panel includes the following features.

- 16 character, 2-line LCD with backlight.
- 6 LEDs.
- Keypad.
- RS232C serial port for connection of local PC.

Local PC Connection

The user can communicate with the GRD110 from a local PC via the RS232C port on the front panel. Using RSM100 software, the user can view and modify settings, monitor real-time metering and analyse recorded data.

Relay Setting and Monitoring (RSM)

GRD110 can be connected to the RSM system via the rear mounted serial communications port, using either RS485 or fibre optic connections (specified at time of order). Using RSM100 software, the user can view and modify settings, monitor real-time metering and analyse recorded data.

A maximum of 32 x 8 relays can be connected to the remote PC in multi-drop mode, by connection via a protocol converter G1PR2, with a maximum data transmission rate of 64kbps. The G1PR2 can be provided with maximum 8 ports and each port supports maximum 32 relays addressing.

Figure 4 and 5 show the configuration of the RSM system and typical displays from the RSM100 software.

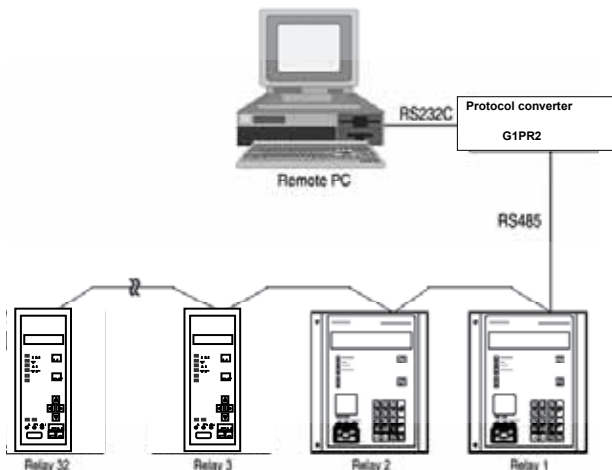

Figure 4 - Relay Setting and Monitoring System

IEC60870-5-103 Communications

GRD110 supports the IEC60870-5-103 communication protocol. This protocol is used for communication with a substation control and monitoring system and is used to transfer measurand data, status data and general commands between the relay and the control system.

Relay Setting

The user can modify relay settings either using the front panel keypad or using the RSM100 software from a local or remote PC. Password protection is available for added security.

Four settings groups are provided, allowing the user to set one group for normal conditions, while the other groups may be set to cover alternative operating conditions.

Using the RSM software, the user can create a settings file on a PC (without being connected to a relay), and store the file ready for download to a relay at a later date.

Binary Outputs

GRD110 provides eight binary output contacts for tripping and alarm, of which seven are user programmable. Each of the programmable binary outputs is driven via a logic gate which can be programmed for OR gate or AND gate operation. Further, each output has a programmable reset characteristic, settable for instantaneous drop-off, delayed drop-off, or for latching operation. If latching operation is selected then an operated relay must be reset by the user, either by pressing the RESET button, by energising a binary input which has been programmed for 'Remote Reset' operation, or by a communications command.

Binary Inputs

GRD110 provides eight programmable binary inputs. Each binary input is individually user-programmable for normal or inverted operation and for delayed pick-up and/or drop-off. Each input can also be used to switch relay operation to a different settings group.

General purpose alarm functions are also included. The user can define a text message for each alarm. Then when inputs associated with that alarm are raised, the defined text is displayed on the LCD.

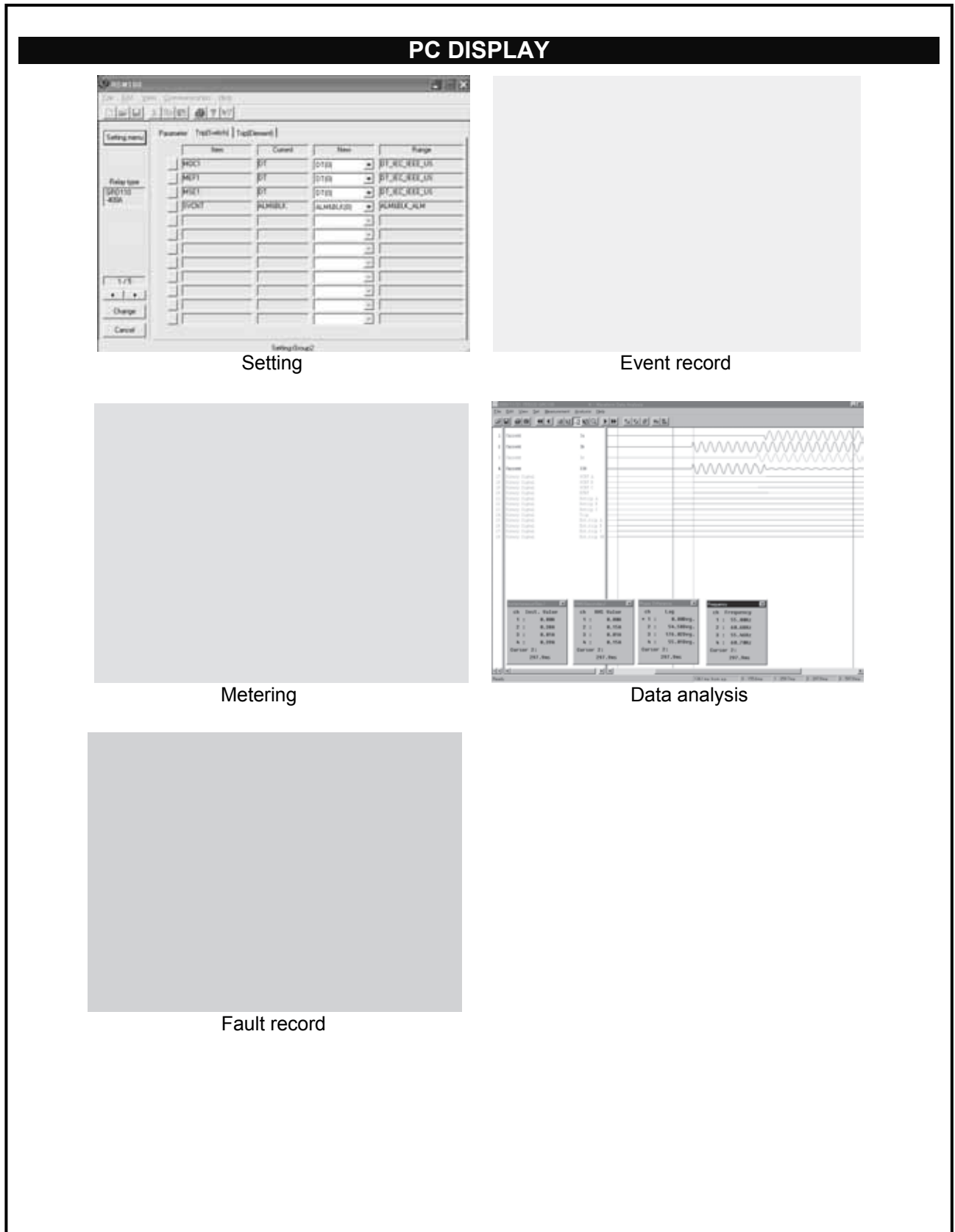

Figure 5 - Relay Setting and Monitoring System - PC Displays

GRD110

TECHNICAL DATA

Ratings	
AC current I _n :	1A or 5A
Frequency:	50Hz or 60Hz
DC auxiliary supply:	110/125Vdc (Operative range: 88 - 150Vdc) 220/250Vdc (Operative range: 176 - 300Vdc) 48/54/60Vdc (Operative range: 38.4 - 72Vdc)
Superimposed AC ripple on DC supply:	maximum 12%
DC supply interruption:	maximum 50ms at 110V
Binary input circuit DC voltage:	110/125Vdc 220/250Vdc 48/54/60Vdc
Overload Ratings	
AC current inputs:	3 times rated current continuous 100 times rated current for 1 second
Burden	
AC phase current inputs:	≤ 0.1VA (1A rating) ≤ 0.3VA (5A rating)
AC earth current inputs:	≤ 0.1VA (1A rating) ≤ 0.3VA (5A rating)
AC sensitive earth inputs:	≤ 0.1VA (1A rating) ≤ 0.2VA (5A rating)
DC power supply:	≤ 10W (quiescent) ≤ 15W (maximum)
Binary input circuit:	≤ 0.5W per input at 110Vdc
Current Transformer Requirements	
Phase Inputs	Typically 5P20 with rated burden according to load, (refer to manual for detailed instructions).
Standard Earth Inputs:	Core balance CT or residual connection of phase CTs.
Sensitive Earth Inputs:	Core balance CT.
Phase Overcurrent Protection	
P/F 1 st , 2 nd Overcurrent threshold:	OFF, 0.04 – 5.00A in 0.01A steps (1A rating) OFF, 0.2 – 25.0A in 0.1A steps (5A rating)
Delay type:	DTL, IEC NI, IEC VI, IEC EI, UK LTI, IEEE MI, IEEE VI, IEEE EI, US CO8 I, US CO2 STI, user configurable
IDMTL Time Multiplier Setting TMS:	0.010 - 1.500 in 0.001 steps
DTL delay:	0.00 - 300.00s in 0.01s steps
Reset Type:	Definite Time or Dependent Time.
Reset Definite Delay:	0.0 - 300.0s in 0.1s steps
Reset Time Multiplier Setting RTMS:	0.010 - 1.500 in 0.001 steps
P/F 3 rd , 4 th Overcurrent thresholds:	OFF, 0.10 - 50.00A in 0.01A steps (1A rating) OFF, 0.5 - 250.0A in 0.1A steps (5A rating)
DTL delay:	0.00 - 300.00s in 0.01s steps

GRD110

Earth Fault Protection	
E/F 1 st , 2 nd Overcurrent threshold:	OFF, 0.02 – 5.00A in 0.01A steps (1A rating) OFF, 0.1 – 25.0A in 0.1A steps (5A rating)
Delay type:	DTL, IEC NI, IEC VI, IEC EI, UK LTI, IEEE MI, IEEE VI, IEEE EI, US CO8 I, US CO2 STI, user configurable
IDMTL Time Multiplier Setting TMS:	0.010 - 1.500 in 0.001 steps
DTL delay:	0.00 - 300.00s in 0.01s steps
Reset Type:	Definite Time or Dependent Time
Reset Definite. Delay:	0.0 - 300.0s in 0.1s steps
Reset Time Multiplier Setting RTMS:	0.010 - 1.500 in 0.001 steps
E/F 3 rd , 4 th thresholds:	OFF, 0.04 - 50.00A in 0.01A steps (1A rating) OFF, 0.2 -250.0A in 0.1A steps (5A rating)
DTL delay:	0.00 - 300.00s in 0.01s steps
Sensitive Earth Fault Protection	
SEF 1 st , 2 nd Overcurrent threshold:	OFF, 0.002 - 0.200A in 0.001A steps (1A rating) OFF, 0.01 - 1.00A in 0.01A steps (5A rating)
Delay Type:	DTL, IEC NI, IEC VI, IEC EI, UK LTI, IEEE MI, IEEE VI, IEEE EI, US CO8 I, US CO2 STI, user configurable
Stage 1 TMS:	0.010 - 1.500 in 0.001 steps
Stage 1 DTL delay:	0.00 - 300.00s in 0.01s steps
Stage 1 Reset Type:	Definite Time or Dependent Time
Stage 1 Reset Def. Delay:	0.0 - 300.0s in 0.1s steps
Stage 1 RTMS:	0.010 - 1.500 in 0.001 steps
Stage 2 DTL delay(for SEF 1 st) :	0.00 - 300.00s in 0.01s steps
SEF 3 rd , 4 th thresholds:	OFF, 0.004 - 1.000A in 0.001A steps (1A rating) OFF, 0.02 - 5.00A in 0.01A steps (5A rating)
DTL delay:	0.00 - 300.00s in 0.01s steps
Phase Undercurrent Protection	
Undercurrent 1 st , 2 nd threshold:	OFF, 0.10 - 2.00A in 0.01A steps (1A rating) OFF, 0.5 - 10.0A in 0.1A steps (5A rating)
DTL Delay:	0.00 - 300.00s in 0.01s steps
Thermal Overload Protection	
$I_{\theta} = k \cdot I_{FLC}$ (Thermal setting):	OFF, 0.40 - 2.00A in 0.01A steps (1A rating) OFF, 2.0 - 10.0A in 0.1A steps (5A rating)
Time constant (τ):	0.5 - 500.0mins in 0.1min steps
Thermal alarm:	OFF, 50% to 99% in 1% steps
Negative Phase Sequence Protection	
NPS 1 st , 2 nd threshold:	OFF, 0.10 - 2.00A in 0.01A steps (1A rating) OFF, 0.5 - 10.0A in 0.1A steps (5A rating)
DTL delay:	0.00 - 300.00s in 0.01s steps
Broken Conductor Protection	
Broken conductor threshold (I_2/I_1):	OFF, 0.10 - 1.00 in 0.01 steps
DTL delay:	0.00 - 300.00s in 0.01s steps
CBF Protection	
CBF threshold:	OFF, 0.10 - 2.00A in 0.01A steps (1A rating) OFF, 0.5 - 10.0A in 0.1A steps (5A rating)
CBF stage 1 DTL:	0.00 - 300.00s in 0.01s steps
CBF stage 2 DTL:	0.00 - 300.00s in 0.01s steps
Inrush Current Detector	
Second harmonic ratio setting (I_{2f} / I_{1f}):	10 - 50% Δ 1
Overcurrent thresholds:	0.10 - 2.00A in 0.01A steps (1A rating) 0.5 - 25.0A in 0.1A steps (5A rating)

GRD110

Autoreclose	
ARC Reclaim Time	0.0 - 600.0s in 0.1s steps
Close Pulse Width	0.01 - 10.00s in 0.01s steps
Lock-out Recovery Time	OFF, 0.1 - 600.0s in 0.1s steps
Sequences	1 - 5 Shots to Lock-out, each trip programmable for inst or Delayed operation
Dead Times(programmable for each shot)	0.01 - 300.00s in 0.01s steps
Accuracy	
Overcurrent Pick-ups:	100% of setting \pm 5%
Overcurrent PU/DO ratio:	\geq 100%, CBF element: \geq 125%
Overcurrent PU/DO ratio:	\geq 95%
Undercurrent Pick-up:	100% of setting \pm 5%
Undercurrent PU/DO ratio:	\leq 100%
Inverse Time Delays:	\pm 5% or 30ms ($1.5 \leq I/I_s \leq 30$)
Definite Time Delays:	\pm 1% or 10ms
Transient Overreach for instantaneous elements:	$<$ -5% for X/R = 100.
Front Communication port - local PC (RS232)	
Connection:	Point to point
Cable type:	Multi-core (straight)
Cable length:	15m (max.)
Connector:	RS232C 9-way D-subminiature connector female
Rear Communication port - remote PC (RS485)	
Connection:	Multidrop (max. 32 relays)
Cable type:	Twisted pair cable with shield
Cable length:	1200m (max.)
Connector:	Screw terminals
Isolation:	2kVac for 1 min.
Transmission rate:	64kpbs for RSM system 9.6, 19.2kpbs for IEC60870-5-103
Rear Communication port - remote PC (Fibre Optic for IEC60870-5-103: option)	
Cable type:	Graded-index multi-mode 62.5/125 μ m type optical fibres
Cable length:	1000m (max.)
Connector:	ST
Transmission rate:	9.6, 19.2kpbs for IEC60870-5-103
Binary Inputs	
Operating Voltage	Typical 74Vdc(min. 70Vdc) for 110Vdc/125Vdc rating Typical 138Vdc(min. 125Vdc) for 220Vdc/250Vdc rating Typical 31Vdc(min. 28Vdc) for 48V/54V/60Vdc rating
Binary Outputs	
Number	8
Ratings:	Make and carry: 4A continuously Make and carry: 10A, 220Vdc for 0.5s (L/R \geq 5ms) Break: 0.1A, 220Vdc (L/R=40ms)
Durability:	Make and carry: 10000 operations Break: 100000 operations
Mechanical design	
Weight	4.5kg
Case color	2.5Y7.5/1(approximation to Munsell value)
Installation	Flush mounting

ENVIRONMENTAL PERFORMANCE

Test	Standards	Details
Atmospheric Environment		
Temperature	IEC60068-2-1/2	Operating range: -10°C to +55°C. Storage / Transit: -25°C to +70°C.
Humidity	IEC60068-2-78	56 days at 40°C and 93% relative humidity.
Enclosure Protection	IEC60529	IP51 (Rear: IP20)
Mechanical Environment		
Vibration	IEC60255-21-1	Response - Class 1 Endurance - Class 1
Shock and Bump	IEC60255-21-2	Shock Response Class 1 Shock Withstand Class 1 Bump Class 1
Seismic	IEC60255-21-3	Class 1
Electrical Environment		
Dielectric Withstand	IEC60255-5	2kVrms for 1 minute between all terminals and earth. 2kVrms for 1 minute between independent circuits. 1kVrms for 1 minute across normally open contacts.
High Voltage Impulse	IEC60255-5	Three positive and three negative impulses of 5kV(peak), 1.2/50µs, 0.5J between all terminals and between all terminals and earth.
Electromagnetic Environment		
High Frequency Disturbance / Damped Oscillatory Wave	IEC60255-22-1 Class 3, IEC61000-4-12 / EN61000-4-12	1MHz 2.5kV applied to all ports in common mode. 1MHz 1.0kV applied to all ports in differential mode.
Electrostatic Discharge	IEC60255-22-2 Class 3, IEC61000-4-2 / EN61000-4-2	6kV contact discharge, 8kV air discharge.
Radiated RF Electromagnetic Disturbance	IEC60255-22-3 Class 3, IEC61000-4-3 / EN61000-4-3	Field strength 10V/m for frequency sweeps of 80MHz to 1GHz and 1.4GHz to 2.7GHz. Additional spot tests at 80, 160, 450, 900, 1850 and 2150MHz.
Fast Transient Disturbance	IEC60255-22-4, IEC61000-4-4 / EN61000-4-4	4kV, 2.5kHz, 5/50ns applied to all inputs.
Surge Immunity	IEC60255-22-5, IEC61000-4-5 / EN61000-4-5	1.2/50µs surge in common/differential modes: HV ports: 2kV/1kV PSU and I/O ports: 2kV/1kV RS485 port: 1kV/0.5kV
Conducted RF Electromagnetic Disturbance	IEC60255-22-6 Class 3, IEC61000-4-6 / EN61000-4-6	10Vrms applied over frequency range 150kHz to 100MHz. Additional spot tests at 27 and 68MHz.
Power Frequency Disturbance	IEC60255-22-7 Class A, IEC61000-4-16 / EN61000-4-16	300V 50Hz for 10s applied to ports in common mode. 150V 50Hz for 10s applied to ports in differential mode. Not applicable to AC inputs.
Conducted and Radiated Emissions	IEC60255-25, EN55022 Class A, IEC61000-6-4 CISPR22 Class A	Conducted emissions: 0.15 to 0.50MHz: <79dB (peak) or <66dB (mean) 0.50 to 30MHz: <73dB (peak) or <60dB (mean) Radiated emissions (at 10m): 30 to 230MHz: <40dB 230 to 1000MHz: <47dB
European Commission Directives		
	89/336/EEC	Compliance with the European Commission Electromagnetic Compatibility Directive is demonstrated according to EN 61000-6-2 and EN 61000-6-4.
	73/23/EEC	Compliance with the European Commission Low Voltage Directive is demonstrated according to EN 50178 and EN 60255-5.

GRD110

ORDERING

Overcurrent Relay

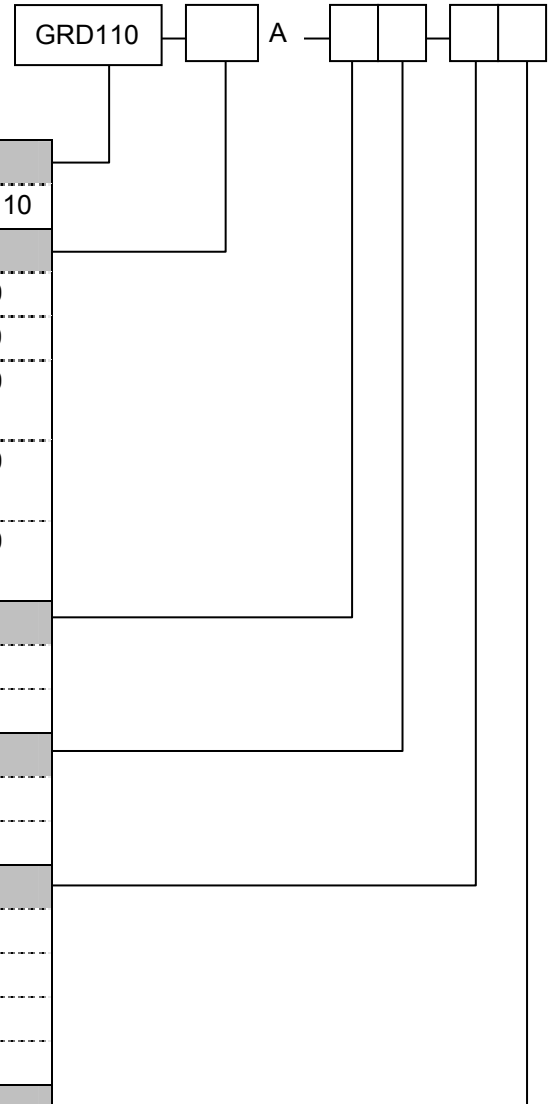

Type:	
Overcurrent Relay	GRD110
Model:	
-Model 110: Earth fault and sensitive earth fault	110
-Model 400: Three phase and earth fault	400
-Model 420: Three phase, earth and sensitive earth fault	420
-Model 500: Three phase and earth fault with auto-reclose	500
-Model 520: Three phase, earth and sensitive earth fault with auto-reclose	520
CT Rating:	
1A	1
5A	2
Frequency:	
50Hz	1
60Hz	2
DC auxiliary supply rating:	
110V/125V	1
220V/250V	2
48V/54V/60V	3
Rear communication port:	
RS485	1
Fibre optic	2
Dual RS485	3

GRD110

TYPICAL APPLICATIONS / CONNECTIONS

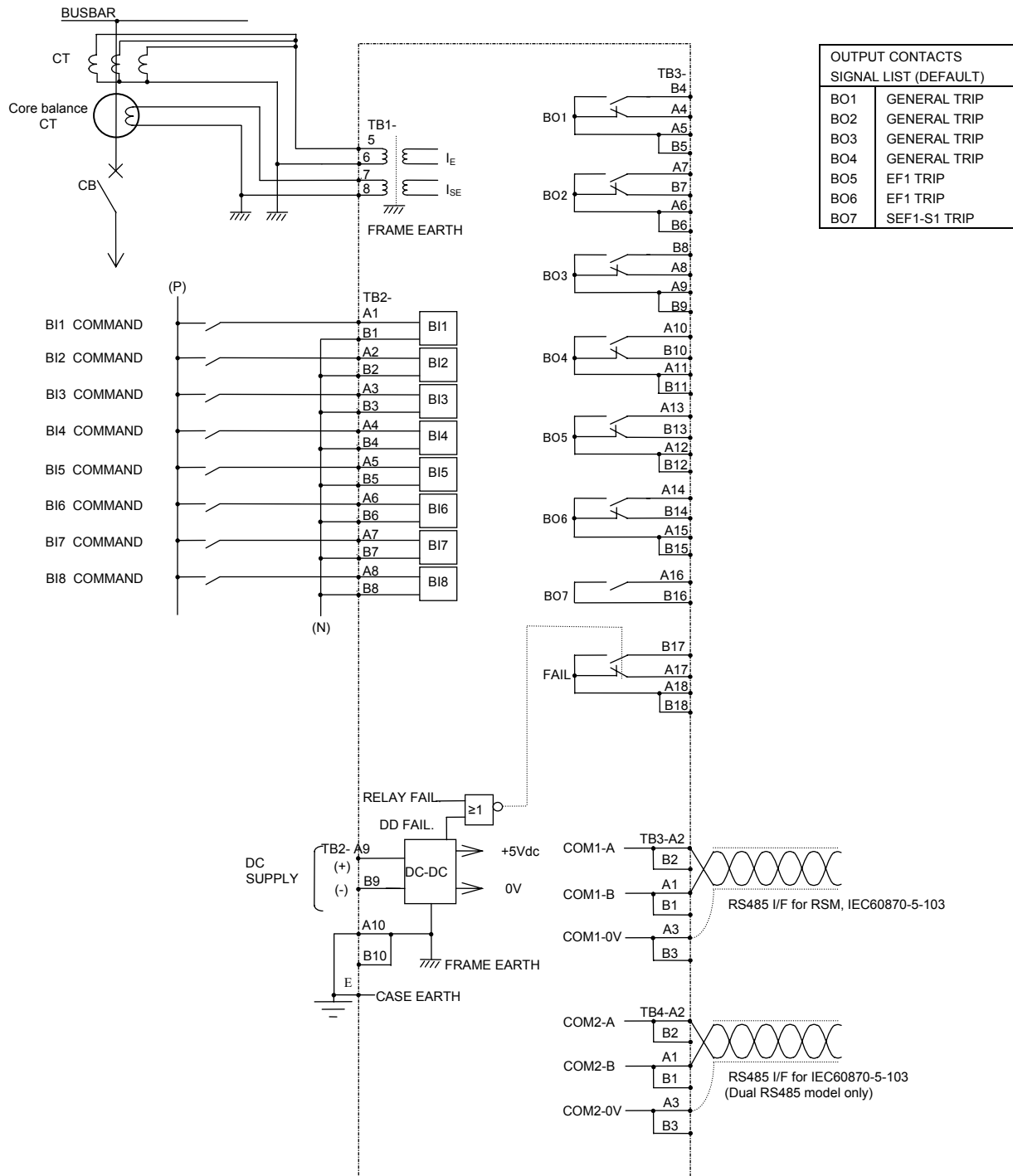

Figure 6 - GRD110-110 Typical Application Diagram

GRD110

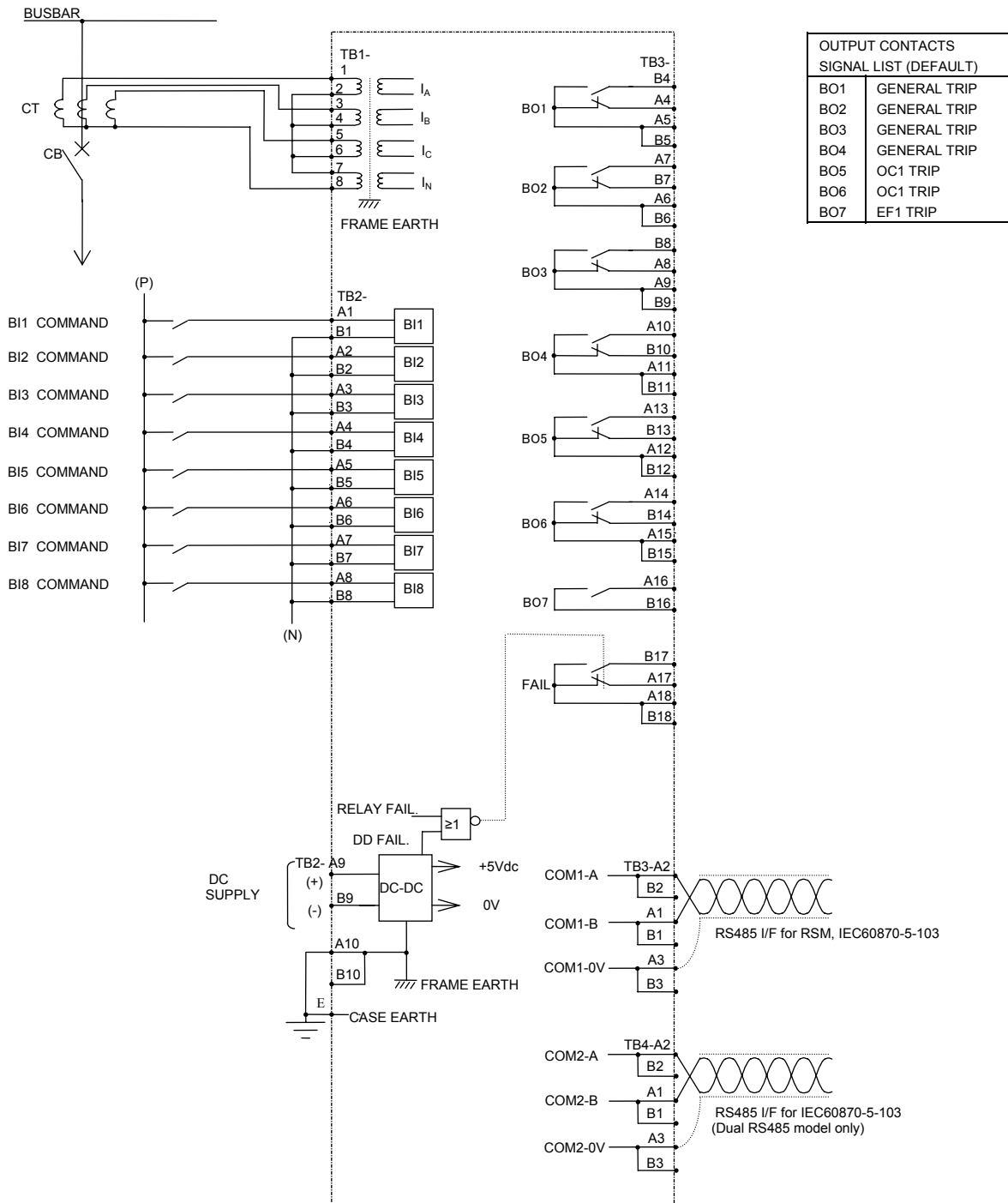

Figure 7 - GRD110-400, 500 Typical Application Diagram

GRD110

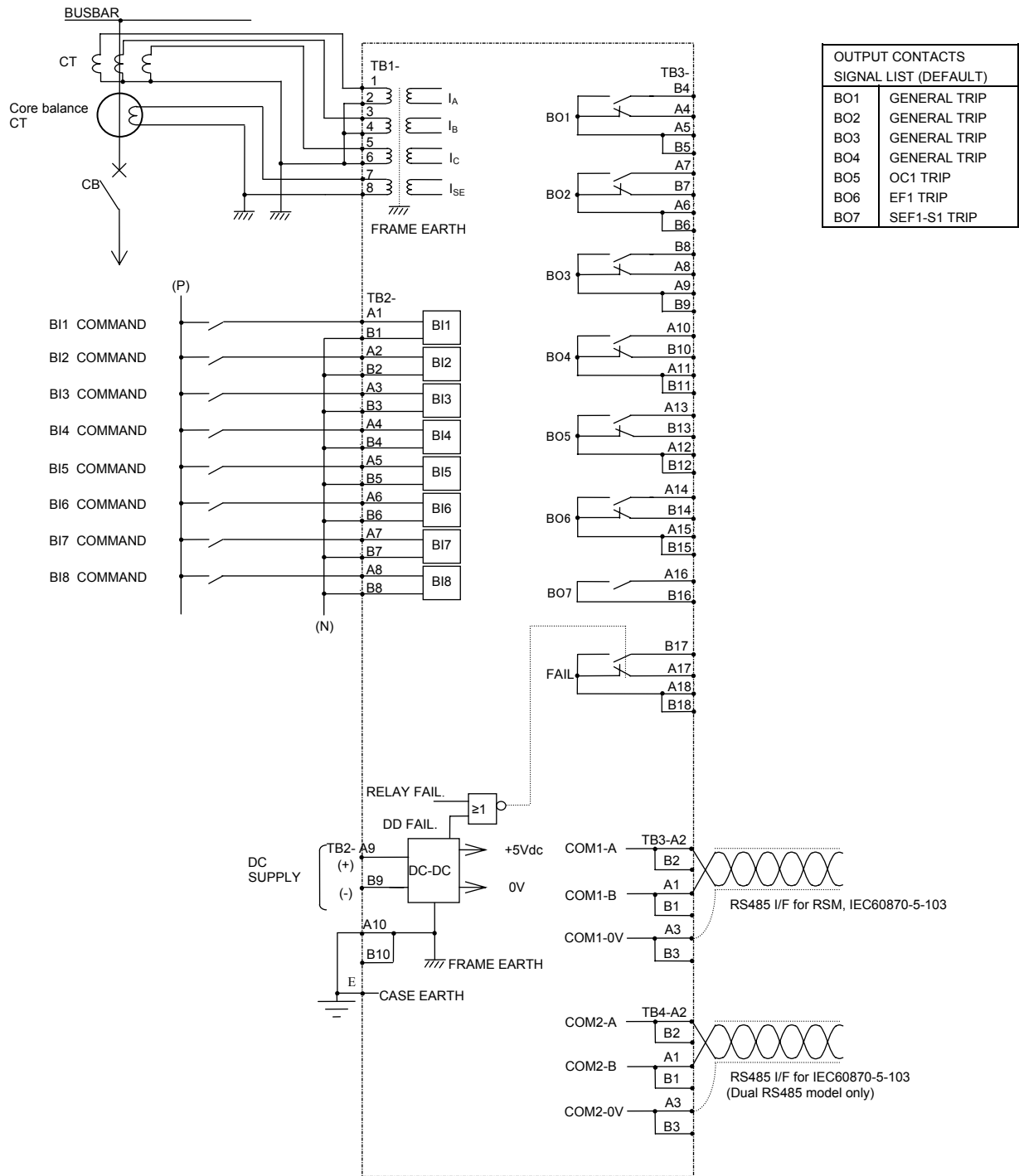

Figure 8 - GRD110-420, 520 Typical Application Diagram

GRD110

RELAY OUTLINE

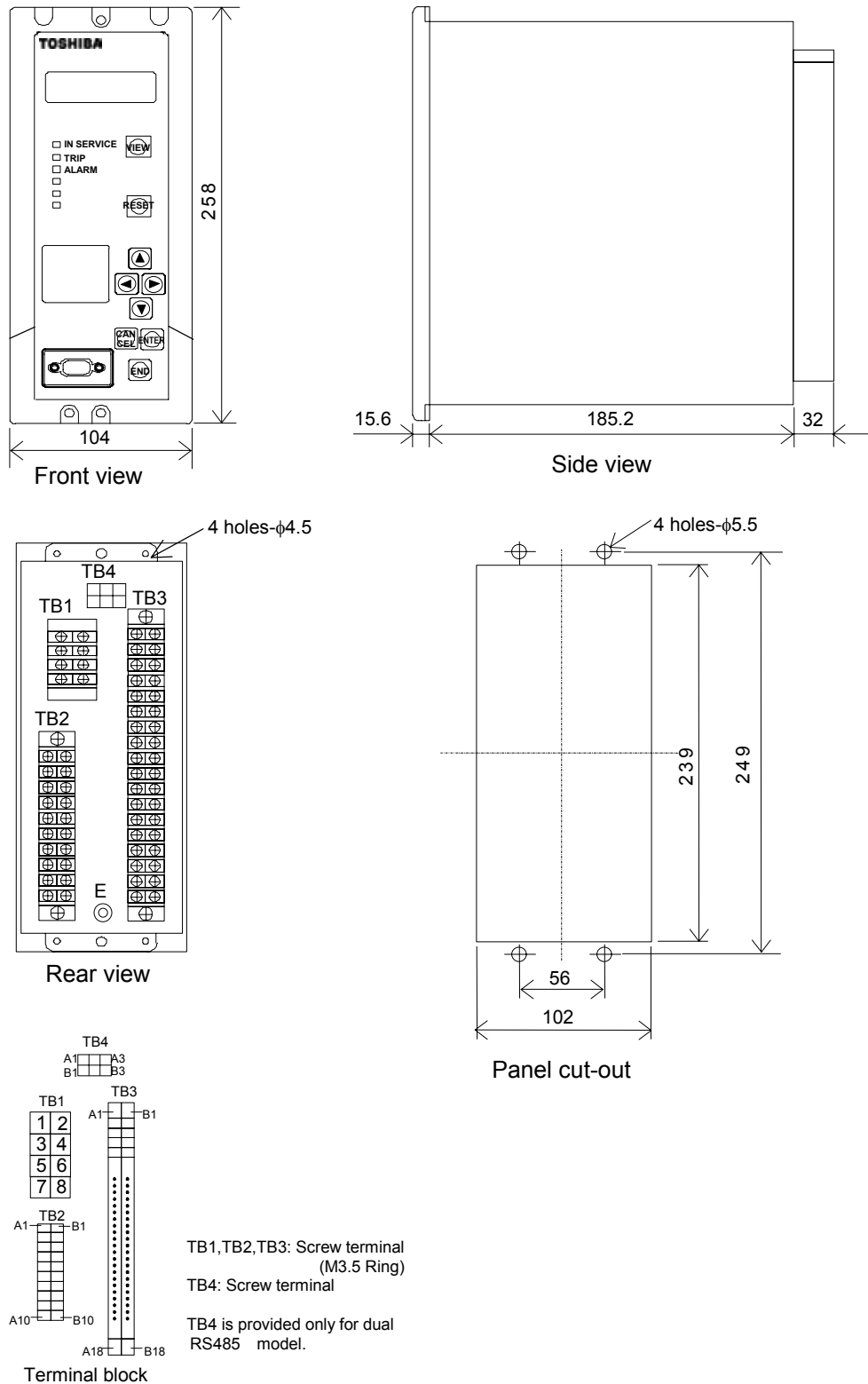

Figure 9 - GRD110 Outline Diagram

Numerical Relay
GRD110
NUMERICAL OVERCURRENT PROTECTION

TOSHIBA

TOSHIBA CORPORATION

Power Systems Company

1-1, SHIBAURA 1-CHOME, MINATO-KU, TOKYO 105-8001, JAPAN

PHONE; +81-3-3457-3644 FAX; +81-3-5444-9168

<http://www.toshiba-relays.com>

The data given in this catalog are subject to change without notice.

6633-2 0803T1