

TOSHIBA

GR Series Relay

N u m e r i c a l R e l a y

GRF100

FREQUENCY, VOLTAGE
PROTECTION

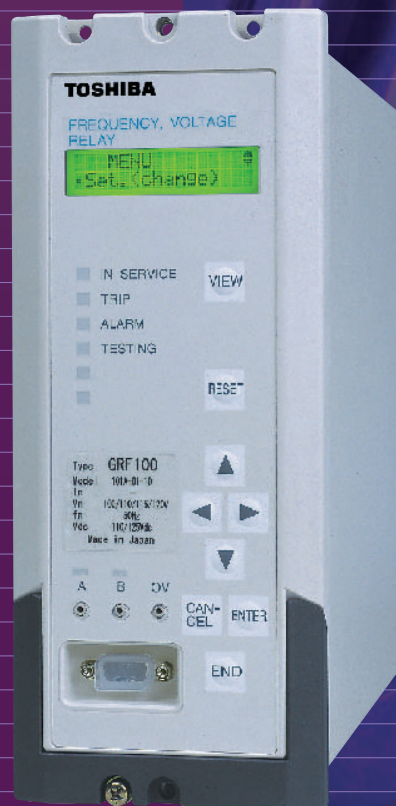

GRF100

FEATURES

- Numerical frequency, and voltage relay
- Four-stage underfrequency and/or overfrequency protection
- Four-stage frequency rate-of-change protection
- Undervoltage block for frequency protection
- Undervoltage and/or overvoltage protection
- Configurable binary outputs
- Automatic monitoring
- Metering and recording functions
- Menu-driven user interface
- Two serial ports for a local PC and a remote PC
- IRIG-B port for external clock

APPLICATION

GRF100 can be applied for underfrequency and/or overfrequency protection and undervoltage and/or overvoltage protection.

The relay provides the following frequency protection schemes.

- Underfrequency protection
- Overfrequency protection
- Frequency rate-of-change protection

In the frequency rate-of-change protection, the GRF100 provides two rate-of-change elements, one operates for frequency decay rate ($-df/dt$) and the other for frequency rise rate ($+df/dt$).

All the frequency protections, underfrequency, overfrequency, frequency decay rate and frequency rise rate, have four operating levels to provide a four-stage protection. Each stage of each protection can be delayed by a timer, or blocked by setting or via a binary input, individually.

All the frequency protections are blocked by undervoltage elements.

GRF100 provides the following undervoltage and overvoltage protection.

- Definite time undervoltage and overvoltage protection
- Inverse time undervoltage and overvoltage protection
- High-speed undervoltage protection

Each of the voltage protections can be delayed by a timer, or blocked by setting or via a binary input, individually.

GRF100 provides the following metering and recording functions.

- Metering
- Fault recording
- Event recording
- Disturbance recording

GRF100 provides the following user interfaces for relay settings or viewing of stored data.

- Relay front panel: LCD, LED display and operation keys
- Local PC
- Remote PC

The relay can be accessed from a local PC or a remote PC through communication ports. A local PC can be connected to the relay via the RS232C port on the front fascia of the relay and a remote PC can be connected to the relay through the RS485 port at the rear of the relay.

GRF100 has two model series, model 101 and model 201. Model 101 provides a single phase-to-phase voltage input, and model 201 provides three phase voltage inputs.

FUNCTIONS

■ Underfrequency Protection

Underfrequency protection is provided to maintain the balance between the power generation capability and the loads. It is also used to maintain the frequency within the normal range by load shedding.

■ Overfrequency Protection

Overfrequency protection is provided to protect synchronous machines from possible damage due to overfrequency conditions.

■ Frequency Rate-of-Change Protection

Rate-of-change of frequency protection is applied to ensure that load shedding occurs very quickly when the frequency change is very rapid.

The frequency rate-of-change protection calculates the gradient of frequency change (df/dt).

GRF100

GRF100 provides two rate-of-change elements, a frequency decay rate element and a frequency rise rate element. These elements provide a mechanism to measure the change (Δf) in frequency over a time interval ($\Delta t=100\text{ms}$), as shown Figure 1.

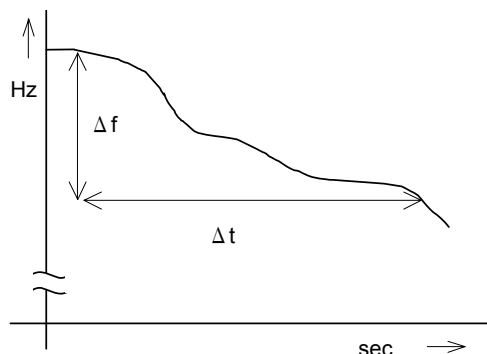

Figure 1. Frequency rate-of-change element

■ Undervoltage Protection

Undervoltage protection is used to protect motors from possible damage caused by voltage drops.

The undervoltage protection has the following six elements:

- Definite time phase-to-phase undervoltage element
- Definite time phase-to-neutral undervoltage element (for model 201)
- Inverse time phase-to-phase undervoltage element
- Inverse time phase-to-neutral undervoltage element (for model 201)
- High-speed phase-to-phase undervoltage element
- High-speed phase-to-neutral undervoltage element (for model 201)

■ Overvoltage Protection

Overvoltage protection is used to protect generators from abnormal voltage rises.

The overvoltage protection has the following four elements:

- Definite time phase-to-phase overvoltage element
- Definite time phase-to-neutral overvoltage element (for model 201)
- Inverse time phase-to-phase overvoltage element
- Inverse time phase-to-neutral overvoltage element (for model 201)

HARDWARE

Figure 2 shows the hardware block diagram of the relay.

The relay is a microprocessor design. The microprocessor performs software functions such as signal processing, protection algorithm, scheme logic, output relay control and management of the user interface.

Analog inputs include a phase-to-phase voltage input or phase voltage inputs. The number of analog inputs depends on the model of the relay.

The internal auxiliary transformers are used to isolate, step down and condition the inputs from the VTs. Their output signals are then converted into digital data for further processing.

The front panel provides a 2 x 16 character, liquid crystal display (LCD) and 9 pushbutton keys to provide local access to the relay menu. There are also 6 light emitting diodes (LED) for visual indication of the status of the relay.

The relay provides three communication ports, RS232C for connection of a local PC, RS485 for a remote PC and IRIG-B for an external clock.

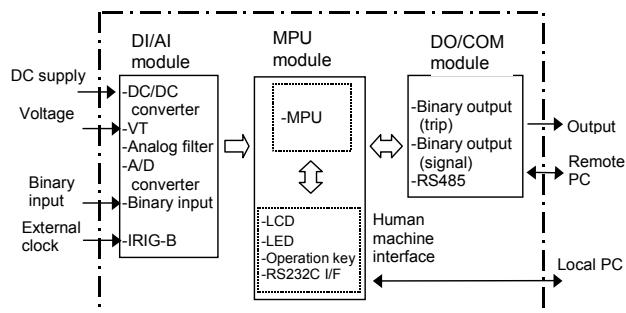

Figure 2. Hardware block diagram

The terminal blocks are located at the rear of the relay providing connections for all input and output circuits.

The relay is housed in the case as shown in Figure 5.

METERING AND RECORDING

■ Metering and Monitoring

The following items of power system data are measured continuously and displayed on the LCD on the relay fascia, at the local PC, and the remote PC when connected, and can be indicated as primary or secondary values.

GRF100

- Frequency (max. and min.) and frequency rate-of-change (df/dt max.)
- Voltages (Each phase voltage and phase angle for model 201)

The user can monitor the following output and status on the LCD and at local/remote PCs

- Relay element output
- Binary input/output

■ Event Record

The most recent 96 time-tagged events are stored with 1 ms resolution. Events recorded are as follows.

- Tripping
- Alarms
- Change of binary input signal
- Change of relay setting
- Relay failure

■ Fault Record

A relay trip initiates fault recording. Time-tagged fault data can be stored for the 8 most recent faults. Fault record items are as follows.

- Date and time
- Tripping mode
- Pre-fault and post-fault voltage and frequency data

■ Disturbance Record

The relay can record 4 analog signals and 12 binary signals. The disturbance recorder is initiated by operation of the frequency element, overvoltage element, under-voltage element and/or relay tripping. Voltage is recorded as an analog data.

Pre-fault recording time is fixed at 300 ms, post-fault recording time is user selectable from 100 ms to 3 s. The maximum number of stored records depends on the post-fault recording time. In the case of a post-fault recording time of 500 ms, up to 20 disturbance records can be stored. The number of the recorded data is displayed on the LCD.

■ Calendar and Time

A calendar and time are provided for time-tagging of recorded data. Synchronisation with the GPS (Global positioning system) is possible using the IRIG-B port.

USER INTERFACE

■ Relay Front Panel

The relay front panel incorporates the following user interfaces. Setting the relay and viewing stored data are possible using the Liquid Crystal Display (LCD) and operation keys.

- 16 character, two line LCD with back light
- 6 Light Emitting Diodes (LEDs)
- Operation keys
- RS232C port
- Monitoring jacks

Figure 3 shows the relay front panel.



Figure 3. Relay front panel

The following items are displayed on the LCD.

- Setting
- Metering
- Event records
- Fault records
- The number of disturbance records
- Any failure message detected by the automatic monitoring

Password protection can be provided from the setting menu on the LCD to provide security for relay setting changes. After the password has been set, the password must be entered to access the setting menu from a local or remote PC as well as on the LCD.

Details of metering, fault records, and relay failures can be monitored by pressing the VIEW key. The VIEW key can be pressed without removing the relay front cover.

Arbitrary signals can be assigned to the two user configurable LEDs.

GRF100

Two monitoring jacks are operable when the test mode is selected in the LCD window. An oscilloscope can be connected to the relay through these jacks. Selection of output signals to the monitoring jacks can be set from the menu.

■ Local PC

The user can communicate with the GRF100 from a local PC via the RS232C port on the relay fascia. The following data can be viewed or analysed on the local PC with RSM100 software.

- Setting
- Metering
- Event records
- Fault records
- Disturbance records

■ Relay Setting and Monitoring (RSM)

GRF100 can be connected to the RSM system via the RS485 interface at the rear of the relay. The user can operate the relay from a remote PC in the same way as from a local PC.

A maximum of 32 x 8 relays can be connected to the remote PC in multi-drop mode, via the protocol converter G1PR2. The G1PR2 can be provided with maximum 8 ports and each port supports maximum 32 relays addressing.

The RSM100 software is also used to communicate with the relay and to view or analyse disturbance records on the remote PC.

Data transmission rate between relays and the protocol converter is 64kbps.

Figure 4 shows the configuration of the RSM system.

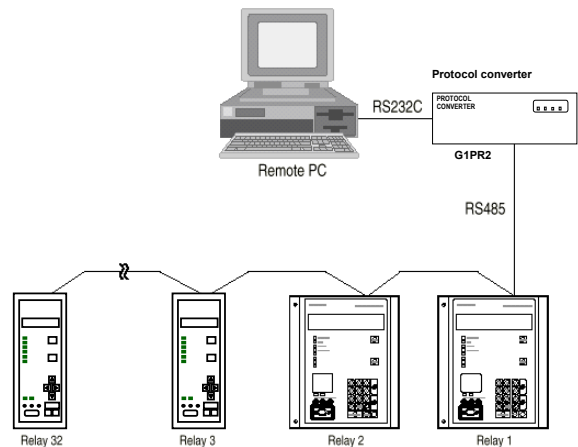

Figure 4. Relay setting and monitoring system

■ IEC60870-5-103 Communications

GRF100 supports the IEC60870-5-103 communication protocol. This protocol is used for communication with a substation control and monitoring system and is used to transfer measurand data, status data and general commands, between the relay and the control system.

■ Relay Setting

The user can input or change settings using the operation keys on the relay fascia or via a local or remote PC with the RSM system.

Password protection is provided to change settings.

Four active setting groups are provided. This allows the user to set one group for normal operating conditions while other groups may be set to cover alternative operating conditions.

■ Configurable Binary Output Contacts

GRF100 is provided with 4 user configurable normally open output contacts for alarm and indication.

■ Binary Inputs

GRF100 is provided with 5 binary inputs.

The binary input circuits are provided with a logic level inversion function.

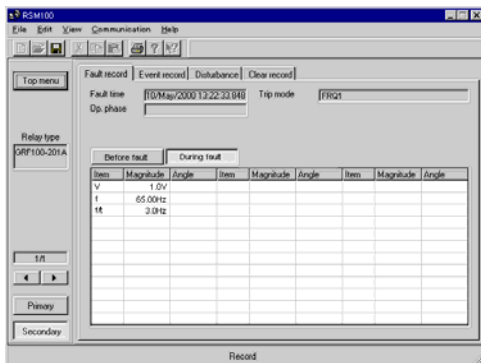

Fault record

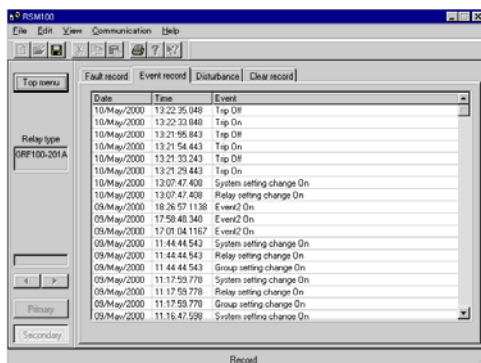

Event record

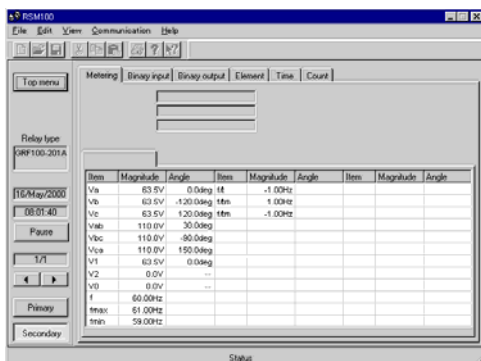

Metering

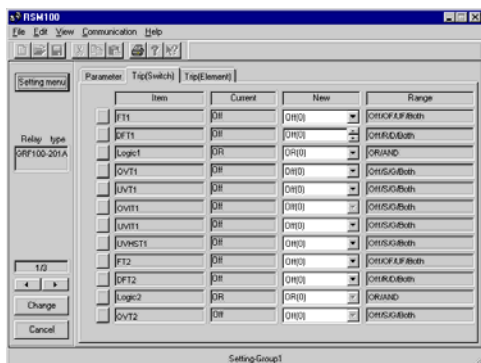

Setting

Automatic Monitor Function

The automatic monitoring function will detect failures, should they occur, that might cause unwanted operation. The items monitored include the following:

- Analog-to-digital converter
- Watchdog timer
- DC power supply circuits
- CPU

Alarms

In the unlikely event that a relay failure should occur, it will be detected by the automatic monitoring function and the LED ALARM on the relay fascia will be illuminated. A binary "RELAY FAILURE" output operates simultaneously and the date/time of any such failure will be stored in the event record.

GRF100

TECHNICAL DATA

Ratings	
AC voltage	100V, 110V, 115V, 120V
Frequency	50Hz or 60Hz
DC power supply	110Vdc/125Vdc (Operative range: 88 to 150Vdc) 220Vdc/250Vdc (Operative range: 176 to 300Vdc) 48Vdc/54Vdc/60Vdc (Operative range: 38.4 to 72Vdc)
AC ripple on DC supply IEC 60255-11	maximum 12%
DC supply interruption IEC 60255-11	
Permissive duration of DC supply voltage interruption to maintain normal operation	maximum 50ms at 110Vdc
Restart time	less than 10s
Binary input circuit DC voltage	110Vdc/125Vdc (Operative range: 88 to 150Vdc) 220Vdc/250Vdc (Operative range: 176 to 300Vdc) 48Vdc/54Vdc/60Vdc(Operative range: 38.4 to 72Vdc)
Overload rating	
AC voltage input	
Model 101	1.2 times rated continuous 1.5 times rated for 1s
Model 201	2 times rated continuous 2.5 times rated for 1s
Burden	
AC voltage input	0.1VA per phase (at rated voltage)
DC power supply	less than 10W (quiescent) less than 15W(operation)
Binary input circuit	0.5W/input at 110Vdc
Frequency protection	
Underfrequency	45.00 to 50.00Hz in 0.01Hz steps
Overfrequency	54.00 to 60.00Hz in 0.01Hz steps 50.00 to 55.00Hz in 0.01Hz steps 60.00 to 66.00Hz in 0.01Hz steps
Frequency rate-of-change	+0.1 to +9.9Hz/s in 0.1Hz/s steps -0.1 to -9.9Hz/s in 0.1Hz/s steps
Operating time	less than 200ms
Timer for stage 1 to 4	0.00 to 100.00s in 0.01s steps
Undervoltage block	40 to 100V in 1V steps
Resetting value	±2%
Accuracy of frequency protection	
Frequency	±0.005Hz at rated frequency ±5%
Frequency change	±0.05Hz
Undervoltage block	±5%
Timer	±2%
Overvoltage protection	
Definite time	
Phase-to-phase element	5 to 190V in 1V steps
Phase-to-neutral element	5 to 100V in 1V steps
Timer for stage 1 to 4	0.00 to 100.00s in 0.01s steps
Inverse time	
Phase-to-phase element	5 to 190V in 1V steps
Phase-to-neutral element	5 to 100V in 1V steps
IDMT	$t = \frac{1}{V/V_s - 1} \times TMS$
Time multiplier (TMS)	Vs: setting value 0.05 to 100.00 in 0.01 steps

GRF100

Undervoltage protection	
Definite time	
Phase-to-phase element	20 to 140V in 1V steps
Phase-to-neutral element	10 to 85V in 1V steps
Timer for stage 1 to 4	0.00 to 100.00s in 0.01s steps
Inverse time	
Phase-to-phase element	20 to 140V in 1V steps
Phase-to-neutral element	10 to 85V in 1V steps
IDMT	$t = \frac{1}{1 - V/V_s} \times TMS$
Time multiplier (TMS)	Vs: setting value 0.05 to 100.00 in 0.01 steps
High speed	
Phase-to-phase element	20 to 140V in 1V steps
Phase-to-neutral element	10 to 85V in 1V steps
Operating time	Less than 20ms
Accuracy of undervoltage and overvoltage protection	
Pickup value	±5%
Timer	±2%
Communication port	
Front communication port (local PC)	
Connection	Point to point
Cable type	Multi-core (straight)
Cable length	15m (max.)
Connector	RS232C 9-pin D-subminiature connector female
Rear communication port (remote PC)	
RS485 I/F	
Transmission data rate for RSM system	64kbps
Connection	Multidrop mode (max. 32 relays)
Connector	Screw terminals
Cable and length	Twisted pair cable, max. 1200m
Isolation	2kVac for 1min.
IRIG-B port	
Connection	BNC connector
Cable type	50 ohm coaxial cable
Binary inputs	
Minimum operating voltage	Typical 74Vdc(min. 70Vdc) for 110Vdc/125Vdc rating Typical 138Vdc(min. 125Vdc) for 220Vdc/250Vdc rating Typical 31Vdc(min. 28Vdc) for 48V/54V/60Vdc rating
Contact ratings	
Trip contacts	
Make and carry	5A continuously, 30A, 290Vdc for 0.5s (L/R=10ms)
Break	0.15A, 290Vdc (L/R=40ms)
Auxiliary contacts	
Make and carry	4A continuously, 10A, 220Vdc for 0.5s (L/R≥5ms)
Break	0.1A, 220Vdc (L/R=40ms)
Durability	
Make and carry	10,000 operations minimum
Break	100,000 operations minimum
Mechanical design	
Weight	5kg
Case color	Munsell No. 10YR8/0.5
Installation	Flush mounting

ENVIRONMENTAL PERFORMANCE

Test	Standards	Details
Atmospheric Environment		
Temperature	IEC60068-2-1/2	Operating range: -10°C to +55°C. Storage / Transit: -25°C to +70°C.
Humidity	IEC60068-2-3	56 days at 40°C and 93% relative humidity.
Enclosure Protection	IEC60529	IP51
Mechanical Environment		
Vibration	IEC60255-21-1	Response - Class 1 Endurance - Class 1
Shock and Bump	IEC60255-21-2	Shock Response Class 1 Shock Withstand Class 1 Bump Class 1
Seismic	IEC60255-21-3	Class 1
Electrical Environment		
Dielectric Withstand	IEC60255-5	2kVrms for 1 minute between all terminals and earth. 2kVrms for 1 minute between independent circuits. 1kVrms for 1 minute across normally open contacts.
High Voltage Impulse	IEC60255-5	Three positive and three negative impulses of 5kV(peak), 1.2/50μs, 0.5J between all terminals and between all terminals and earth.
Electromagnetic Environment		
High Frequency Disturbance / Damped Oscillatory Wave	IEC60255-22-1 Class 3, IEC61000-4-12 / EN61000-4-12	1MHz 2.5kV applied to all ports in common mode. 1MHz 1.0kV applied to all ports in differential mode.
Electrostatic Discharge	IEC60255-22-2 Class 3, IEC61000-4-2 / EN61000-4-2	6kV contact discharge, 8kV air discharge.
Radiated RF Electromagnetic Disturbance	IEC60255-22-3 Class 3, IEC61000-4-3 / EN61000-4-3	Field strength 10V/m for frequency sweeps of 80MHz to 1GHz and 1.7GHz to 2.2GHz. Additional spot tests at 80, 160, 450, 900 and 1890MHz.
Fast Transient Disturbance	IEC60255-22-4, IEC61000-4-4 / EN61000-4-4	4kV, 2.5kHz, 5/50ns applied to all inputs.
Surge Immunity	IEC60255-22-5, IEC61000-4-5 / EN61000-4-5	1.2/50μs surge in common/differential modes: HV ports: 2kV/1kV PSU: 2kV/1kV RS485: 1kV
Conducted RF Electromagnetic Disturbance	IEC60255-22-6 Class 3, IEC61000-4-6 / EN61000-4-6	10Vrms applied over frequency range 150kHz to 100MHz. Additional spot tests at 27 and 68MHz.
Power Frequency Disturbance	IEC60255-22-7, IEC61000-4-16 / EN61000-4-16	300V 50Hz for 10s applied to ports in common mode. 150V 50Hz for 10s applied to ports in differential mode. Not applicable to AC inputs.
Conducted and Radiated Emissions	IEC60255-25, EN55022 Class A, IEC61000-6-4 / EN61000-6-4	Conducted emissions: 0.15 to 0.50MHz: <79dB (peak) or <66dB (mean) 0.50 to 30MHz: <73dB (peak) or <60dB (mean) Radiated emissions (at 30m): 30 to 230MHz: <30dB 230 to 1000MHz: <37dB

GRF100

Test	Standards	Details
European Commission Directives		
	89/336/EEC	Compliance with the European Commission Electromagnetic Compatibility Directive is demonstrated according to EN 61000-6-2 and EN 61000-6-4.
	73/23/EEC	Compliance with the European Commission Low Voltage Directive is demonstrated according to EN 50178 and EN 60255-5.

PROTOCOL CONVERTER G1PR2 (OPTION)

Ratings		
Power supply:	110Vdc/100Vac	Operative range: 88 - 150Vdc of 110Vdc rated voltage 80 - 120Vac of 100Vac rated voltage
	220Vdc/200Vac	Operative range: 170 - 300Vdc of 220Vdc rated voltage 200 - 240Vac of 200Vac rated voltage
	48Vdc	Operative range: 38.4 - 72Vdc
Burden:	less than 20W	
Communication port		
RS232C interface		
Connector type	RS232C 9-pin D-subminiature connector female	
Cable type	Multi-core (straight)	
RS485 interface		
Connector	Screw terminals (Phoenix Contact, FRONT type)	
Cable type	Twisted pair cable	
Optical interface		
Operative Range:	less than 1.2km with 62.5/125µm GI fibre (3dB/km)	
Wavelength:	820nm	
Connector type:	ST	
Fibre type:	62.5/125µm glass fibre	
IRIG-B		
Connector	Screw terminals (Phoenix Contact, FRONT-MSTB type)	
Mechanical design		
Enclosure Protection	IEC60529, IP20	
Weight	5 kg	
Installation	Flush mounting	
Atmospheric Environment		
Temperature	IEC60068-2-1/2	Operating range: -10°C to +55°C. Storage / Transit: -25°C to +70°C.
Humidity	IEC60068-2-3	56 days at 40°C and 93% relative humidity.

GRF100

ORDERING

1. Frequency, Voltage Relay

(1) Single RS485 port

Relay type:	
Frequency, voltage relay	GRF100
Model:	
Single phase input	101
Three phase inputs	201
Frequency:	
50Hz	1
60Hz	2
DC power supply rating:	
110V/125V	1
220V/250V	2
48V/54V/60V	3

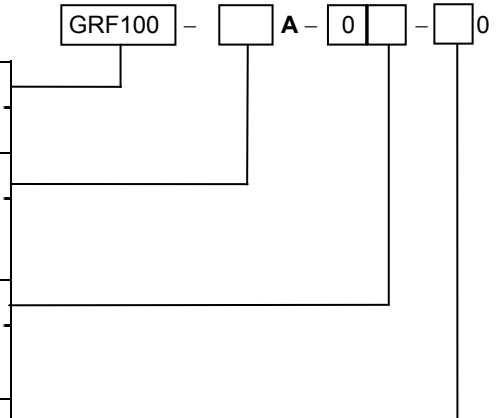

(2) Dual RS485 port (Available for IEC60870-5-103 Communication)

Relay type:	
Frequency, voltage relay	GRF100
Model:	
Single phase input	101
Three phase inputs	201
Ratings:	
50Hz, 110V/125Vdc	1
60Hz, 110V/125Vdc	2
50Hz, 220V/250Vdc	5
60Hz, 220V/250Vdc	6
50Hz, 48V/54V/60Vdc	A
60Hz, 48V/54V/60Vdc	B
Communications:	
Dual RS485	3

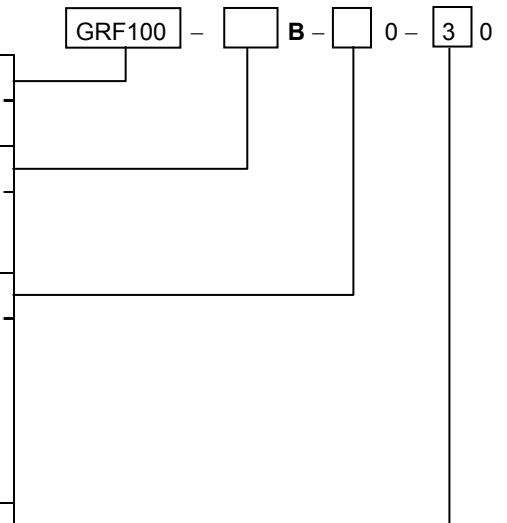

GRF100

2. Protocol Converter (Option)

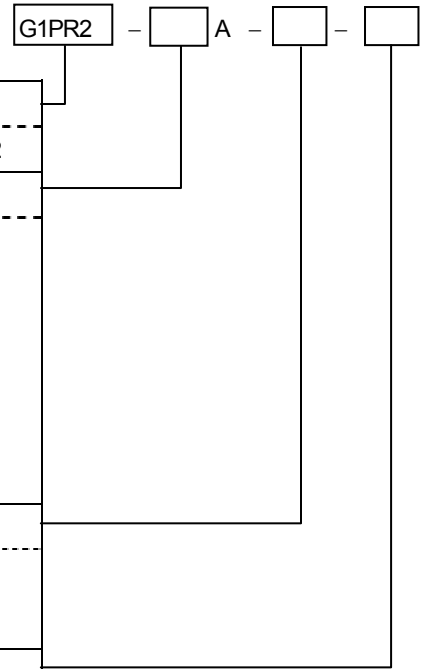

Type:	
Protocol converter	G1PR2
Model:	
1 port, Electrical signal (RS485)	101
4 ports, Electrical signal (RS485)	104
8 ports, Electrical signal (RS485)	108
8 ports, Electrical signal (RS485): Max. 8, Optical signal: Max. 1	118
8 ports, Electrical signal (RS485): Max. 8, Optical signal: Max. 4	148
8 ports, Electrical signal (RS485): Max. 4, Optical signal: Max. 8	184
1 port, Electrical signal (RS485) or Optical signal	111
1 port, Optical signal	110
4 ports, Optical signal	140
8 ports, Optical signal	180
AC power supply rating:	
AC 100/DC 110V	10
AC 200/DC 220V	50
DC 48V	A0
External time synchronisation:	
None.	00
Provided. (IRIG-B)	10

GRF100

RELAY OUTLINE

Outline of GRF100

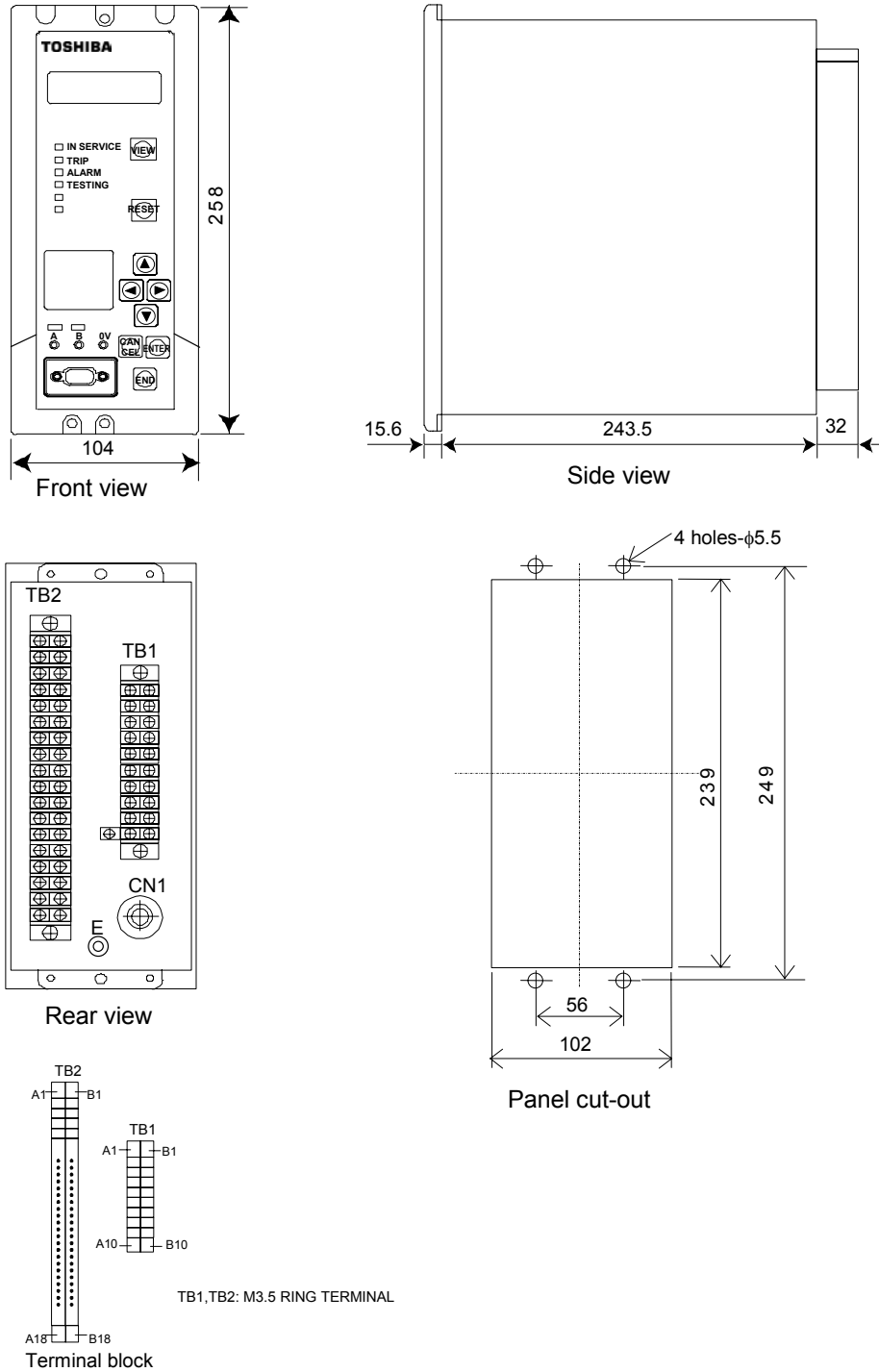

Figure 5. Outline of GRF100

GRF100

EXTERNAL CONNECTION DIAGRAM

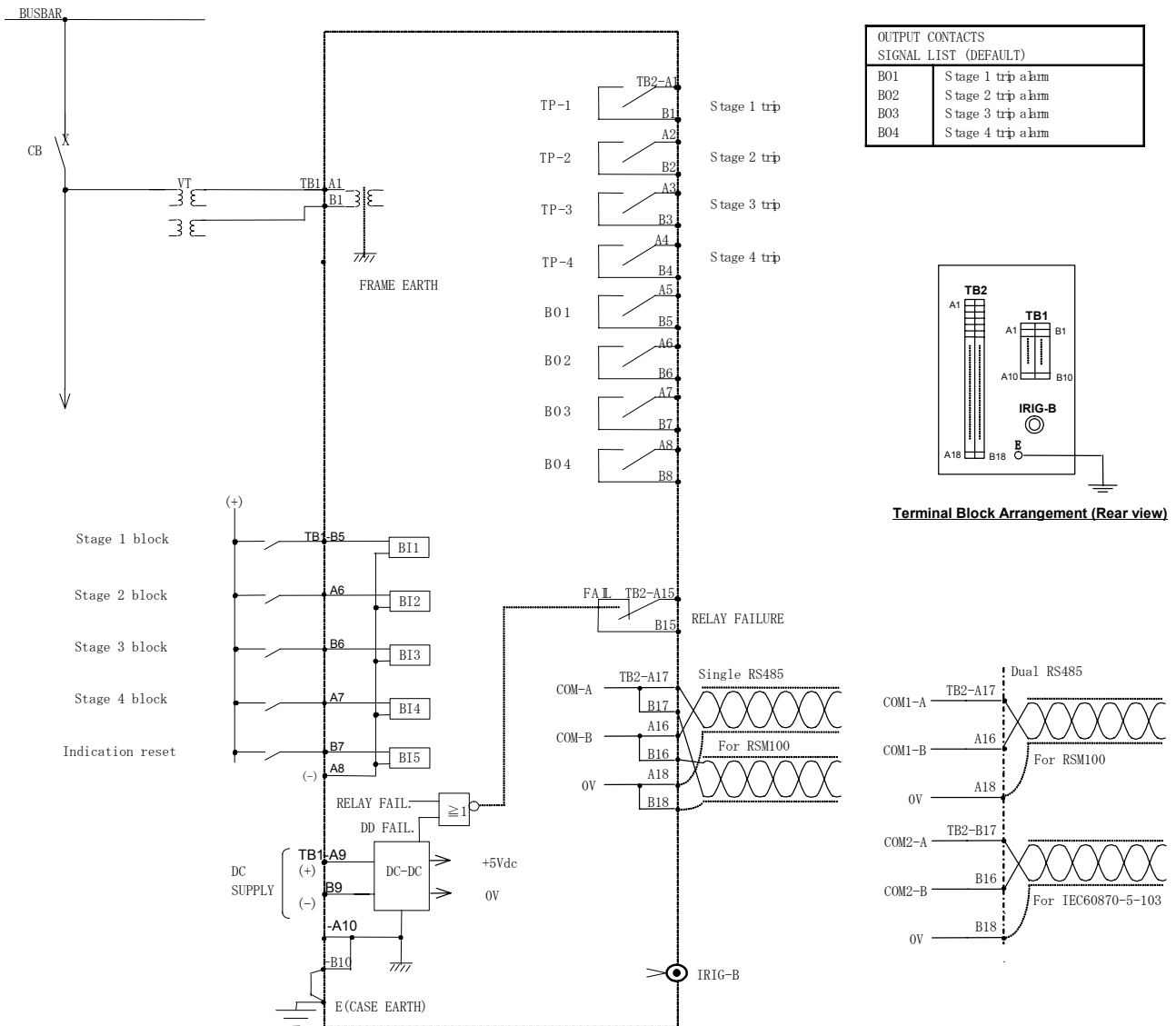

Figure 6. Typical External connection of Model 101

GRF100

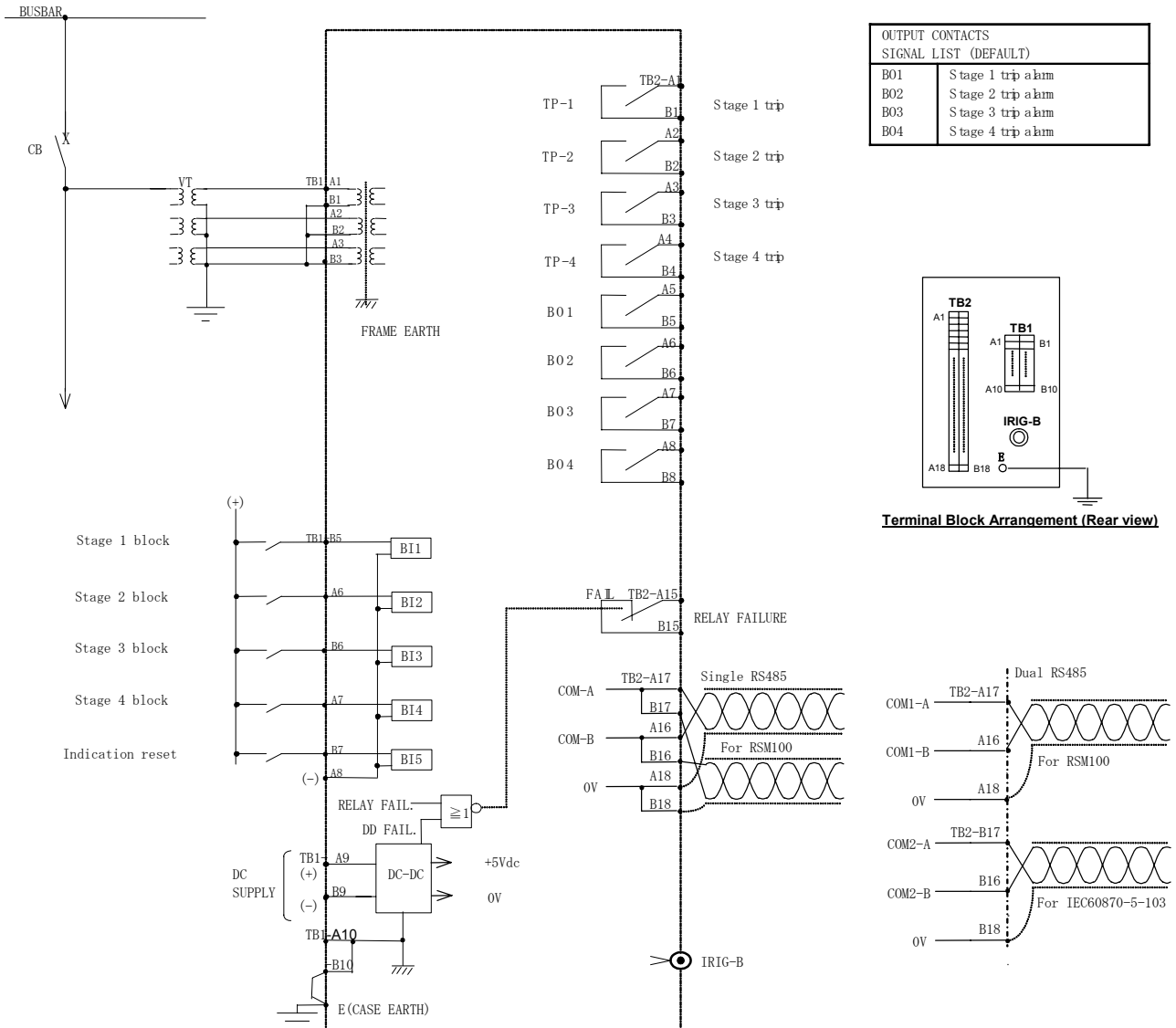

Figure 7. Typical External connection of Model 201

Numerical Relay

GPRF100

FREQUENCY, VOLTAGE PROTECTION

TOSHIBA

TOSHIBA CORPORATION

Industrial and Power Systems & Services Company

1-1, SHIBAURA 1-CHOME, MINATO-KU, TOKYO 105-8001, JAPAN

PHONE; +81-3-3457-3644 FAX; +81-3-5444-9168

http://www.toshiba.co.jp/f-ene/tands/english/protect/f_pc_top.htm

The data given in this catalog are subject to change without notice.

6637-1 0508T1