

TOSHIBA

Leading Innovation >>>

GR Series Relay

N u m e r i c a l R e l a y

GRR100

AUTORECLOSING
PROTECTION



GRR100

FEATURES

- Numerical autoreclosing function
- Single-shot, single-phase and/or three-phase autoreclose scheme for one or two circuit breakers
- Multi-shot (selectable between 2 and 4) three-phase autoreclose scheme for one circuit breaker
- Integrated synchronism check function for autoreclose
- Autoreclose counter
- Configurable binary outputs
- Automatic monitoring
- Metering and recording functions
- Menu-driven user interface
- Two serial ports for a local PC and a remote PC
- IEC60870-5-103 communication
- IRIG-B port for external clock

APPLICATION

GRR100 is a numerical single or multi-shot auto-reclosing relay suitable for applications to either a single circuit breaker or two circuit breakers configured in a one-and-a-half breaker busbar system.

GRR100 can be applied to:

- Single-shot, single-phase and/or three-phase autoreclose schemes for one or two circuit breakers
- Multi-shots (selectable between 2 and 4) three-phase autoreclose scheme for one circuit breaker
Single phase reclosing is applicable for the first shot of the multi-shot autoreclose sequence

GRR100 provides the following metering and recording functions.

- Metering
- Fault recording
- Event recording
- Disturbance recording
- Autoreclose count

GRR100 provides the following user interfaces for relay settings or viewing of stored data.

- Relay front panel: LCD, LED display and operation keys
- Local PC
- Remote PC

The relay can be accessed from a local PC or a remote PC through communication ports.

A local PC can be connected to the relay via the RS232C port on the front fascia of the relay. Either one or two rear ports (RS485) are provided for connection to a remote PC and for IEC60870-5-103 communication with a substation control and automation system.

GRR100 has six models as shown in Table 1.

Table 1 Relay Model and Function

Function	Model					
	101A	201A	101B	201B	111B	211B
1CB autoreclose	x		x		x	
2CB autoreclose		x		x		x
Multi-shots (up to 4) three-phase autoreclose	x		x		x	
Single-shot single- and/or three-phase autoreclose	x	x	x	x	x	x
Voltage check (OVL, UVL, OVB, UVB)	x	x	x	x	x	x
Synchronism check: (SYN):						
- Phase angle check (SY θ)	x	x	x	x	x	x
- Voltage check (line and busbar: SYOVL, SYOVB, SYUVL, SYUVB)	x	x	x	x	x	x
- Voltage difference check between line and busbar (SYDV)					x	x
- Frequency difference check between line and busbar (SYDf)					x	x
IEC60870-5-103 communication			x	x	x	x

FUNCTIONS

■ Single-shot Autoreclose

When using only single-shot reclosing, any of the three reclosing options can be selected; single-phase, three-phase, and single-/three-phase autoreclosing.

■ Multi-shot Autoreclose

In a multi-shot autoreclose application, two to four shots can be selected. The first shot is selected from any of the three reclosing scheme, single-phase, three-phase, and single- and/or three-phase reclosing. If reclosing by the first shot fails, three-phase tripping and reclosing is applied for the second to fourth shots.

■ One-and-a-half Breaker Scheme

Model 200 performs two-circuit-breaker autoreclosing for a one-and-a-half breaker busbar configuration.

Only the single-shot reclosing scheme is available. Single-phase, three-phase and single- and/or three-phase reclosing can be applied for the two circuit breakers.

■ Synchronism Check Function

GRR100 has an integrated synchronism check element to verify the phase angle difference between line and busbar voltage when using the three-phase reclosing scheme.

Figure 1 shows the voltage and synchronism check zone.

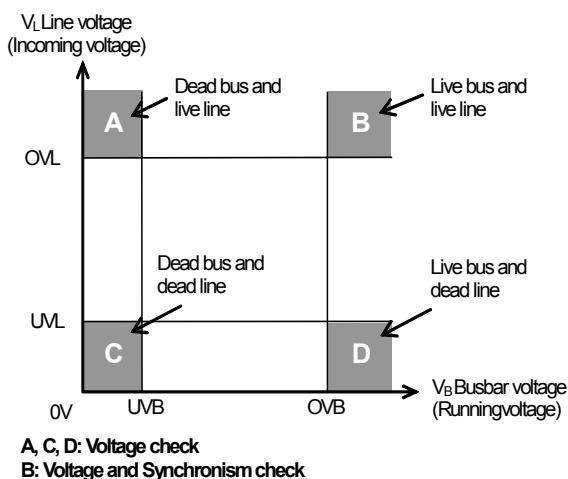

Figure 1. Voltage and Synchronism Check

Individual output signals for synchronising can also be used for manual circuit breaker closing.

The synchronism check element SYN1 is composed of the following check functions:

SY θ : checks the phase angle difference between the line voltage (incoming voltage) and the busbar voltage (running voltage)

SYUV/OV: check the line voltage and the busbar voltage

SYDV for Models 111 and 211: checks the voltage difference between the line voltage (incoming voltage) and the busbar voltage (running voltage)

SYDf for Models 111 and 211: checks the frequency difference between the line voltage (incoming voltage) and the busbar voltage (running voltage)

Figure 2 shows the characteristics of the synchronism check element.

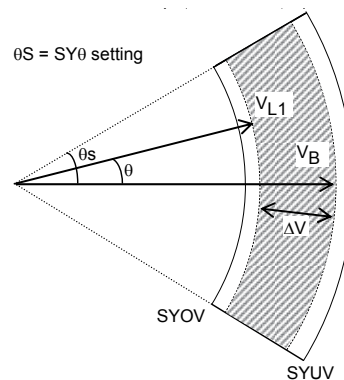

Figure 2. Synchronism check element

Models 111B and 211B directly detect a slip cycle (frequency difference). In other models, however, a detected slip cycle is determined by the following equation:

$$f = \frac{\theta_s}{180^\circ \times \text{TSYN}}$$

where,

f : slip cycle

θ_s : synchronism check angle setting

TSYN: synchronism check timer setting

HARDWARE

Figure 3 shows the hardware block diagram of the relay.

The relay is a microprocessor design. The microprocessor performs software functions such as signal processing, protection algorithm, scheme logic, output relay control and management of the user interface.

Phase voltage analogue inputs are provided. The internal auxiliary transformers are used to isolate, step down and condition the inputs from the VTs. Their output signals are then converted into digital data for further processing.

GRR100

The front panel provides a 2x16 character, liquid crystal display (LCD) and 9 pushbutton keys to provide local access to the relay menu. There are also 6 light emitting diodes (LED) for visual indication of the status of the relay.

The relay provides three communication ports, RS232C for connection of a local PC, RS485 for a remote PC and IRIG-B for an external clock.

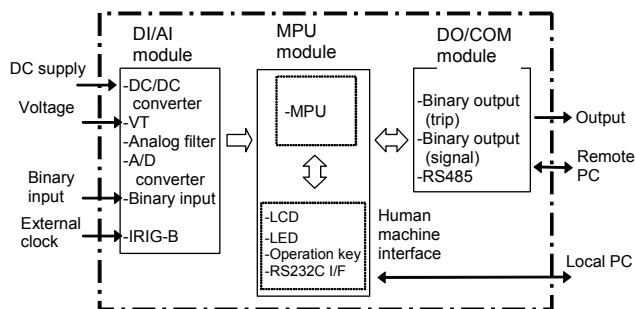

Figure 3. Hardware block diagram

The terminal blocks are located at the rear of the relay providing connections for all input and output circuits.

The relay is housed in the case as shown in Figure 6.

METERING AND RECORDING

■ Metering and Monitoring

Voltages (V_B , V_{L1} , V_{L2}) are measured continuously and displayed on the LCD on the relay fascia, at the local PC, and the remote PC when connected, and can be indicated as primary or secondary values.

The user can monitor the following output and status on the LCD and at local/remote PCs

- Relay element output
- Binary input/output

■ Event Record

The most recent 96 time-tagged events are stored with 1 ms resolution. Events recorded are as follows.

- Reclosing
- Trip (Reclose initiation) signal
- Alarms
- Change of binary input signal
- Change of relay setting
- Relay failure

■ Fault Record

A trip signal initiates fault recording. Time-tagged fault

data can be stored for the 8 most recent faults. Fault record items are as follows.

- Date and time
- Trip phase
- Reclosing mode
- Pre-fault and post-fault voltage data

■ Disturbance Record

The relay can record 3 analogue signals (V_B , V_{L1} , V_{L2}) and 11 binary signals. The disturbance recorder is initiated by a tripping and/or reclosing signal.

Pre-fault recording time is fixed at 300ms, and post-fault recording time is user selectable from 100ms to 3s. The maximum number of stored records depends on the post-fault recording time. In the case of a post-fault recording time of 500 ms, up to 20 disturbance records can be stored. The number of the recorded data is displayed on the LCD.

■ Calendar and Time

A calendar and time are provided for time-tagging of recorded data. Synchronisation with the GPS (Global positioning system) is possible using the IRIG-B port.

USER INTERFACE

■ Relay Front Panel

The relay front panel provides the following user interfaces. Setting the relay and viewing stored data are possible using the Liquid Crystal Display (LCD) and operation keys.

- 16 character, two line LCD with back light
- 6 Light Emitting Diodes (LEDs)
- Operation keys
- RS232C port
- Monitoring jacks

Figure 4 shows the relay front panel.



Figure 4. Relay front panel

GRR100

The following items are displayed on the LCD.

- Setting
- Metering
- Event records
- Fault records
- The number of disturbance records
- Any failure message detected by the automatic monitoring

Password protection can be provided from the setting menu on the LCD to provide security for relay setting changes. After the password has been set, the password must be entered to access the setting menu from a local or remote PC as well as on the LCD.

Details of metering, fault records, and relay failures can be monitored by pressing the VIEW key. The VIEW key can be pressed without removing the relay front cover.

Arbitrary signals can be assigned to the two user configurable LEDs.

Two monitoring jacks are operable when the test mode is selected in the LCD window. An oscilloscope can be connected to the relay through these jacks. Selection of output signals to the monitoring jacks can be set from the menu.

■ Local PC

The user can communicate with the GRR100 from a local PC via the RS232C port on the relay fascia. The following data can be viewed or analysed on the local PC with RSM100 software.

- Setting
- Metering
- Event records
- Fault records
- Disturbance records

■ Relay Setting and Monitoring (RSM)

GRR100 can be connected to the RSM system via the RS485 interface at the rear of the relay. The user can operate the relay from a remote PC in the same way as from a local PC.

A maximum of 32 x 8 relays can be connected to the remote PC in multi-drop mode, via the protocol converter G1PR2. The G1PR2 can be provided with maximum 8 ports and each port supports maximum 32 relays addressing.

The RSM100 software is also used to communicate with the relay and to view or analyse disturbance records on the remote PC.

Data transmission rate between relays and the protocol converter is 64kbps.

Figure 5 shows the configuration of the RSM system.

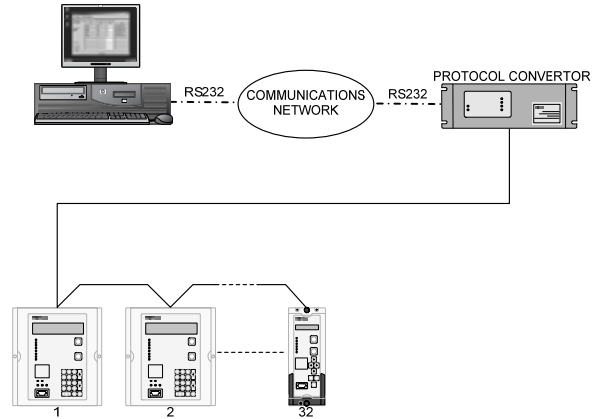

Figure 5. Relay setting and monitoring system

■ IEC60870-5-103 Communications

GRR100-xxxB model supports the IEC60870-5-103 communication protocol. This protocol is used for communication with a substation control and monitoring system and is used to transfer measurand data, status data and general commands, between the relay and the control system.

■ Relay Setting

The user can input or change settings using the operation keys on the relay fascia or via a local or remote PC with the RSM system.

Password protection is provided to change settings.

Four active setting groups are provided. This allows the user to set one group for normal operating conditions while other groups may be set to cover alternative operating conditions.

■ Configurable Binary Output Contacts

GRR100 is provided with 10 user configurable normally open output contacts for reclose command and alarm.

■ Binary Inputs

GRR100 is provided with 8 binary inputs for initiation of the GRR100, CB conditions and indication reset.

The binary input circuit is provided with a logic level inversion function.

AUTOMATIC MONITORING

■ Automatic Monitoring Function

The automatic monitoring function will detect failures, should they occur, that might cause unwanted operation. The items monitored include the following:

- Analogue-digital converter
- Watchdog timer
- DC power supply circuits
- CPU

■ Alarms

In the unlikely event that a relay failure should occur, it will be detected by the automatic monitoring function and the LED ALARM on the relay fascia will be illuminated. A binary "RELAY FAILURE" output operates simultaneously and the date/time of any such failure will be stored in the event record.

PC DISPLAY



Fault record

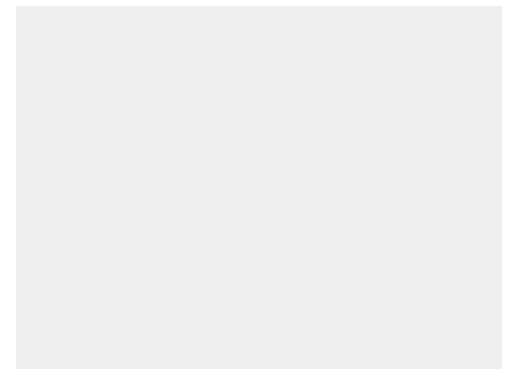

Event record

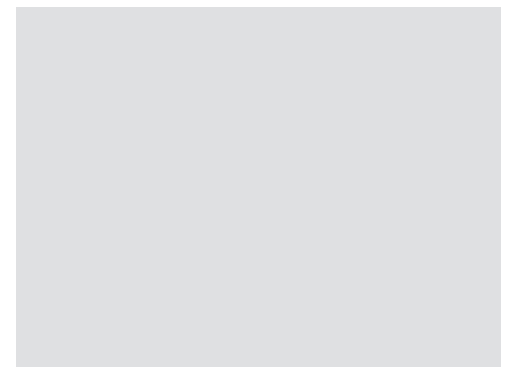

Metering

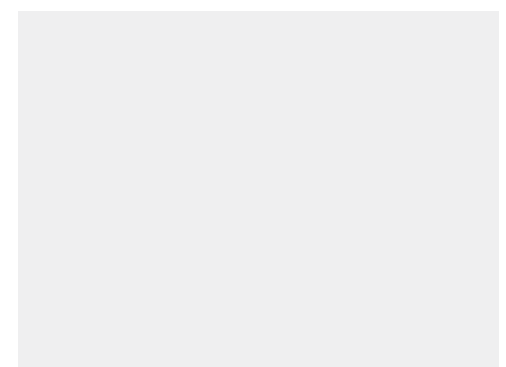

Setting

GRR100

TECHNICAL DATA

Ratings	
AC Voltage	100V, 110V, 115V, 120V
Frequency	50Hz or 60Hz
DC power supply	110Vdc/125Vdc (Operative range: 88 - 150Vdc) 220Vdc/250Vdc (Operative range: 176 - 300Vdc) 48Vdc/54Vdc/60Vdc (Operative range: 38.4 - 72Vdc)
AC ripple on DC supply IEC 60255-11	maximum 12%
DC supply interruption IEC 60255-11	
Permissive duration of DC supply voltage interruption to maintain normal operation	maximum 50ms at 110Vdc
Restart time	less than 10s
Binary input circuit DC voltage	110Vdc/125Vdc 220Vdc/250Vdc 48Vdc/54Vdc/60Vdc
Overload rating	
AC voltage input	1.4 times rated continuous 2 times rated for 1 second
Burden	
AC voltage circuit	less than 0.1VA per phase
DC power supply	less than 10W (quiescent) less than 15W(operation)
Binary input circuit	less than 0.5W/input at 110Vdc
Autoreclose setting	
Number of shots	1 to 4
Timer settings	
Dead time for single-phase autoreclose	0.01 to 10.00s in 0.01 steps
Dead time for three-phase autoreclose	0.01 to 100.00s in 0.01 steps
Multi-shot dead line time	5.0 to 300.0s in 0.1s steps
Multi-shot reset time	5.0 to 300.0s in 0.1s steps
Reclaim time	5 to 300s in 1s steps
Pulse width of reclosing signal output	0.1 to 10.0s in 0.1s steps
Autoreclose reset time	0.01 to 100.00s in 0.01 steps
Reset time for developing fault	0.01 to 10.00s in 0.01 steps
One-and-a-half breaker scheme	
Follower breaker autoreclose delay time	0.1 to 10.0s in 0.1s steps
Voltage and synchronism check element	
UV element (UVB, UVL)	10 to 150V in 1V steps
OV element (OVB, OVL)	10 to 150V in 1V steps
Synchronism check angle (SYθ)	5 to 75° in 1° steps
Busbar or line dead check (SYUVB, SYUVL)	10 to 150V in 1V steps
Busbar or line live check (SYOVB, SYOVL)	10 to 150V in 1V steps
Voltage difference check (SYDV)	0 to 150V in 1V steps
Frequency difference check (SYDf)	0.01 to 2.00Hz in 0.01Hz steps
Synchronism check time (TSYN)	0.01 to 10.00s in 0.01s steps
Voltage check time (TDBL, TLBD, TDBD)	0.01 to 10.00s in 0.01s steps
Operating time of synchronism check element	less than 50ms
Operating time of UV and OV element	less than 40ms

GRR100

Communication port	
Front communication port (local PC)	
Connection	Point to point
Cable type	Multi-core (straight)
Cable length	15m (max.)
Connector	RS232C 9-pin D-subminiature connector female
Rear communication port (remote PC)	
RS485 I/F	
Transmission data rate	64kbps for RSM system 9.6kbps, 19.2kbps for IEC60870-5-103
Connection	Multi-drop mode (max. 32 relays)
Connector	Screw terminals
Cable and length	Twisted pair cable with shield, max. 1200m
Isolation	2kVac for 1min.
IRIG-B port	
Connection	BNC connector
Cable type	50 ohm coaxial cable
Binary inputs	
Operating voltage	Typical 74Vdc(min. 70Vdc) for 110V/125Vdc rating Typical 138Vdc(min. 125Vdc) for 220V/250Vdc rating Typical 31Vdc(min. 28Vdc) for 48V/54V/60Vdc rating
Contact ratings	
Auxiliary contacts	
Make and carry	4A continuously, 10A, 220Vdc for 0.5s (L/R≥5ms)
Break	0.1A, 220Vdc (L/R=40ms)
Durability	
Make and carry	10,000 operations minimum
Break	100,000 operations minimum
Mechanical design	
Weight	5kg
Case colour	2.5Y7.5/1(approximation to Munsell value)
Installation	Flush mounting

ENVIRONMENTAL PERFORMANCE

Test	Standards	Details
Atmospheric Environment		
Temperature	IEC60068-2-1/2	Operating range: -10°C to +55°C. Storage / Transit: -25°C to +70°C.
Humidity	IEC60068-2-3	56 days at 40°C and 93% relative humidity.
Enclosure Protection	IEC60529	IP51 (Rear: IP20)
Mechanical Environment		
Vibration	IEC60255-21-1	Response - Class 1 Endurance - Class 1
Shock and Bump	IEC60255-21-2	Shock Response Class 1 Shock Withstand Class 1 Bump Class 1
Seismic	IEC60255-21-3	Class 1
Electrical Environment		
Dielectric Withstand	IEC60255-5	2kVrms for 1 minute between all terminals and earth. 2kVrms for 1 minute between independent circuits. 1kVrms for 1 minute across normally open contacts.
High Voltage Impulse	IEC60255-5	Three positive and three negative impulses of 5kV(peak), 1.2/50µs, 0.5J between all terminals and between all terminals and earth.
Electromagnetic Environment		
High Frequency Disturbance / Damped Oscillatory Wave	IEC60255-22-1, IEC61000-4-12 / EN61000-4-12	1MHz 2.5kV applied to all ports in common mode. 1MHz 1.0kV applied to all ports in differential mode.
Electrostatic Discharge	IEC60255-22-2 Class 3, IEC61000-4-2 / EN61000-4-2	6kV contact discharge, 8kV air discharge.
Radiated RF Electromagnetic Disturbance	IEC60255-22-3, IEC61000-4-3 / EN61000-4-3	Field strength 10V/m for frequency sweeps of 80MHz to 1GHz and 1.4GHz to 2.7GHz. Additional spot tests at 80, 160, 450, 900, 1850, 2150MHz.
Fast Transient Disturbance	IEC60255-22-4, IEC61000-4-4 / EN61000-4-4	4kV, 2.5kHz, 5/50ns applied to all inputs.
Surge Immunity	IEC60255-22-5, IEC61000-4-5 / EN61000-4-5	1.2/50µs surge in common/differential modes: HV ports: 2kV/1kV PSU and I/O ports: 2kV/1kV RS485 port: 1kV/0.5kV
Conducted RF Electromagnetic Disturbance	IEC60255-22-6, IEC61000-4-6 / EN61000-4-6	10Vrms applied over frequency range 150kHz to 100MHz. Additional spot tests at 27 and 68MHz.
Power Frequency Disturbance	IEC60255-22-7 Class A, IEC61000-4-16 / EN61000-4-16	300V 50Hz for 10s applied to ports in common mode. 150V 50Hz for 10s applied to ports in differential mode. Not applicable to AC inputs.
Conducted and Radiated Emissions	IEC60255-25, IEC61000-6-4 / EN61000-6-4 CISPR22 Class A	Conducted emissions: 0.15 to 0.50MHz: <79(peak) or <66(mean) dB(µV) 0.50 to 30MHz: <73(peak) or <60(mean) dB(µV) Radiated emissions (at 10m): 30 to 230MHz: <40dB 230 to 1000MHz: <47dB
European Commission Directives		
	89/336/EEC	Compliance with the European Commission Electromagnetic Compatibility Directive is demonstrated according to EN 61000-6-2 and EN 61000-6-4.
	73/23/EEC	Compliance with the European Commission Low Voltage Directive is demonstrated according to EN 50178 and EN 60255-5.

GRR100

PROTOCOL CONVERTER G1PR2 (OPTION)

Ratings		
Power supply:	110Vdc/100Vac	Operative range: 88 - 150Vdc of 110Vdc rated voltage 80 - 120Vac of 100Vac rated voltage
	220Vdc/200Vac	Operative range: 170 - 300Vdc of 220Vdc rated voltage 200 - 240Vac of 200Vac rated voltage
Burden:	48Vdc	Operative range: 38.4 - 72Vdc
	less than 20W	
Communication port		
RS232C interface	RS232C 9-pin D-subminiature connector female	
Connector type	Multi-core (straight)	
Cable type		
RS485 interface	Screw terminals (Phoenix Contact, FRONT type)	
Connector	Twisted pair cable	
Cable type		
Optical interface	less than 1.2km with 62.5/125µm GI fibre (3dB/km)	
Operative Range:	820nm	
Wavelength:	ST	
Connector type:	62.5/125µm glass fibre	
Fibre type:		
IRIG-B	Screw terminals (Phoenix Contact, FRONT-MSTB type)	
Connector		
Mechanical design		
Enclosure Protection	IEC60529, IP20	
Weight	5 kg	
Installation	Flush mounting	
Atmospheric Environment		
Temperature	IEC60068-2-1/2	Operating range: -10°C to +55°C. Storage / Transit: -25°C to +70°C.
Humidity	IEC60068-2-3	56 days at 40°C and 93% relative humidity.

GRR100

ORDERING

1. Autoreclose Relay

(1) Single RS485 port

	G	R	R	1	0	0	-		0	1	A	-	0		-		0
Relay Model																	
Autoreclose for single breaker scheme									1								
Autoreclose for two breaker scheme									2								
Frequency																	
50Hz														1			
60Hz														2			
DC Power Supply Rating																	
110/125V																	1
220/250V																	2
48/54/60V																	3

(2) Dual RS485 port (Available for IEC60870-5-103 Communication)

	G	R	R	1	0	0	-			1	B	-		0	-	3	0
Relay Model																	
Autoreclose for single breaker scheme																	
Autoreclose for two breaker scheme																	
Check Synchronising																	
Phase Angle Difference										0							
Phase Angle/Voltage/Frequency Difference										1							
Rating																	
50Hz, 110/125Vdc																	1
60Hz, 110/125Vdc																	2
50Hz, 220/250Vdc																	5
60Hz, 220/250Vdc																	6
50Hz, 48/54/60Vdc																	A
60Hz, 48/54/60Vdc																	B

GRR100

2. Protocol Converter (Option)

	G	1	P	R	2	-				A	-			-			0
Model																	
1 port, Electrical signal (RS485)	1	0	1														
4 ports, Electrical signal (RS485)	1	0	4														
8 ports, Electrical signal (RS485)	1	0	8														
8 ports, Electrical signal (RS485): Max. 8, Optical signal: Max. 1	1	1	8														
8 ports, Electrical signal (RS485): Max. 8, Optical signal: Max. 4	1	4	8														
8 ports, Electrical signal (RS485): Max. 4, Optical signal: Max. 8	1	8	4														
1 port, Electrical signal (RS485) or Optical signal	1	1	1														
1 port, Optical signal	1	1	0														
4 ports, Optical signal	1	4	0														
8 ports, Optical signal	1	8	0														
Power supply rating																	
AC100/DC110V												1	0				
AC200/DC220V												5	0				
DC48V												A	0				
External time synchronisation																	
None.																	0
Provided. (IRIG-B)																	1

GRR100

RELAY OUTLINE

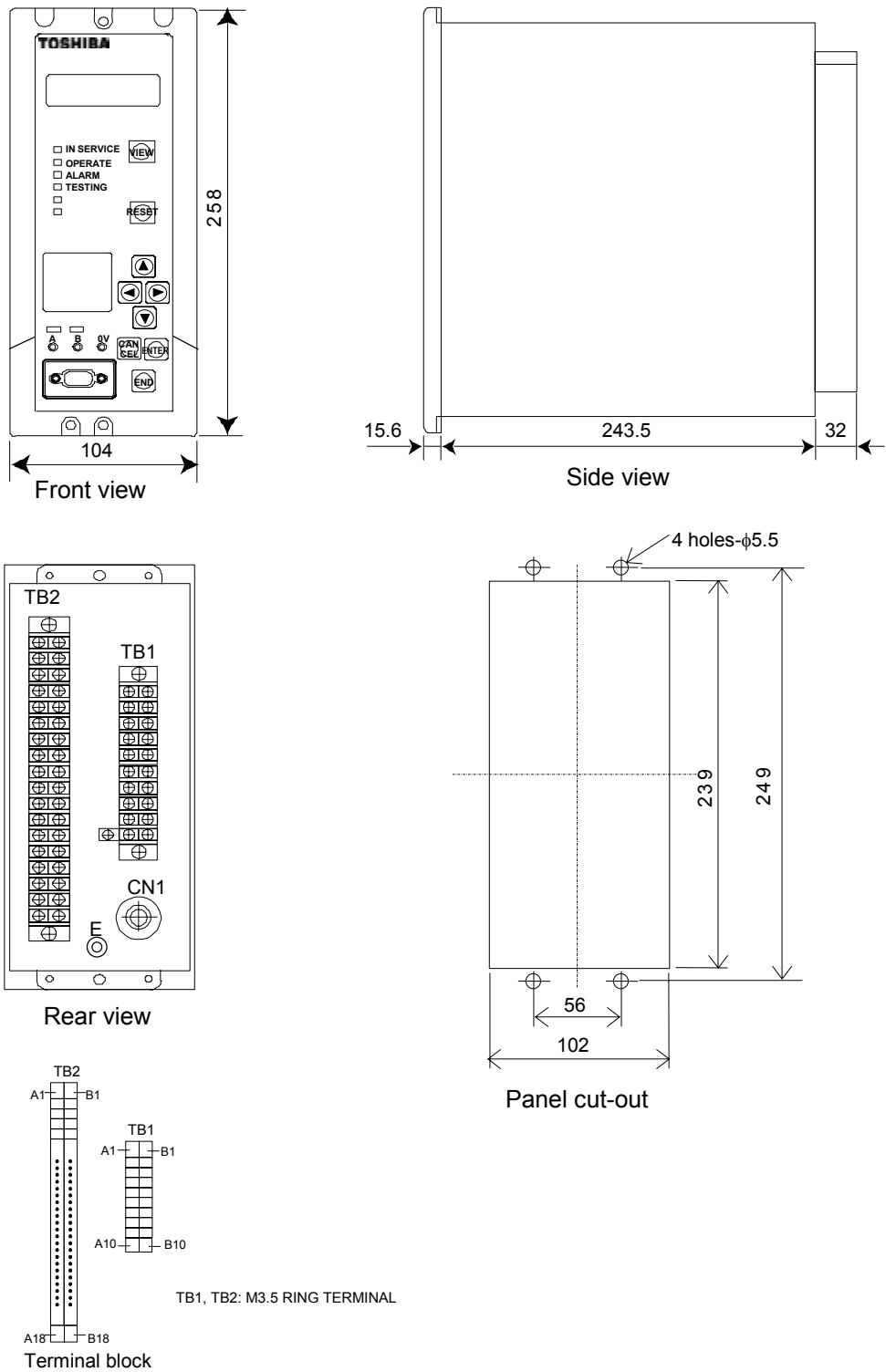

Figure 6. Outline of GRR100

EXTERNAL CONNECTION DIAGRAM

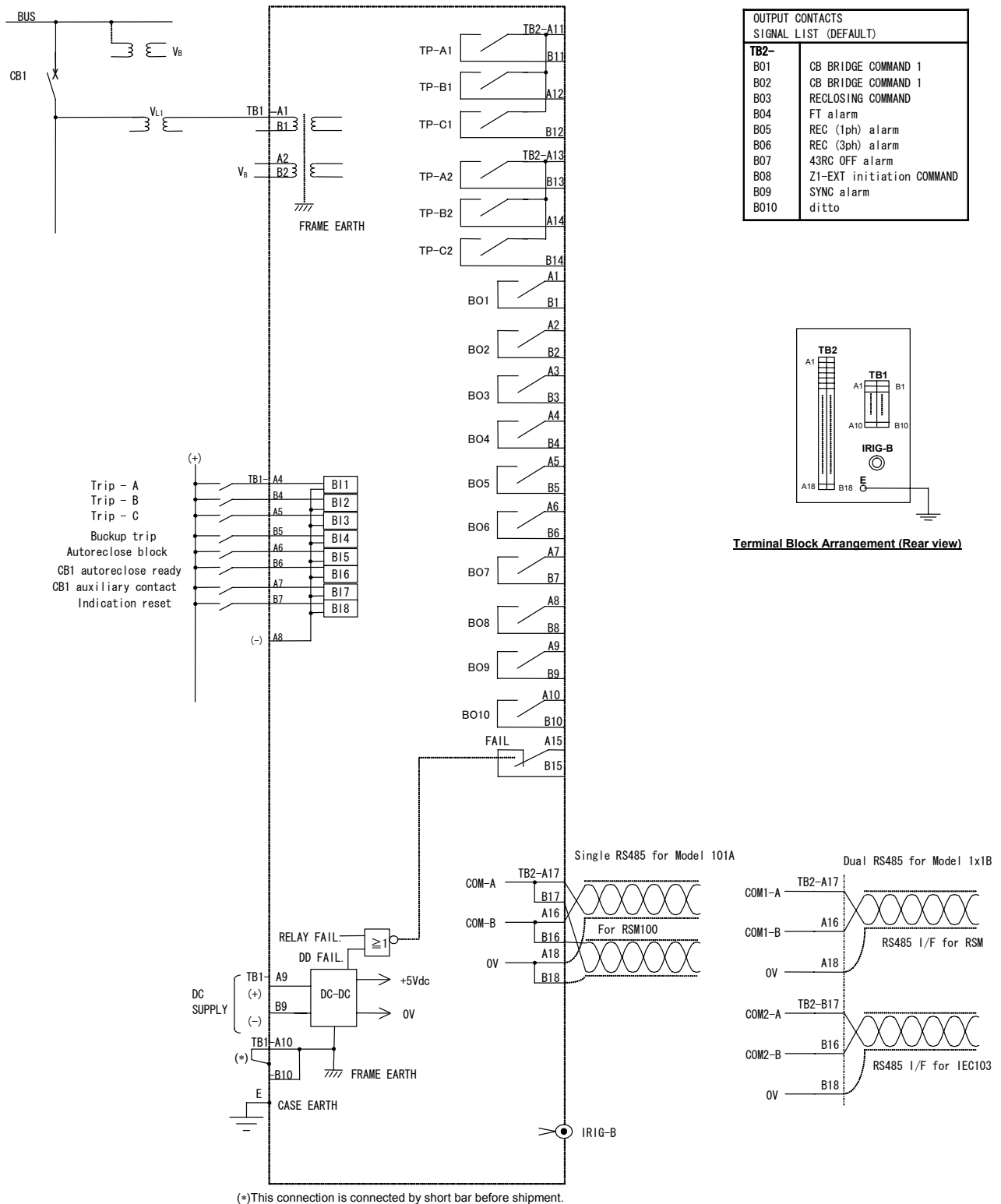

Figure 7. Typical External connection for Model 1x1

GRR100

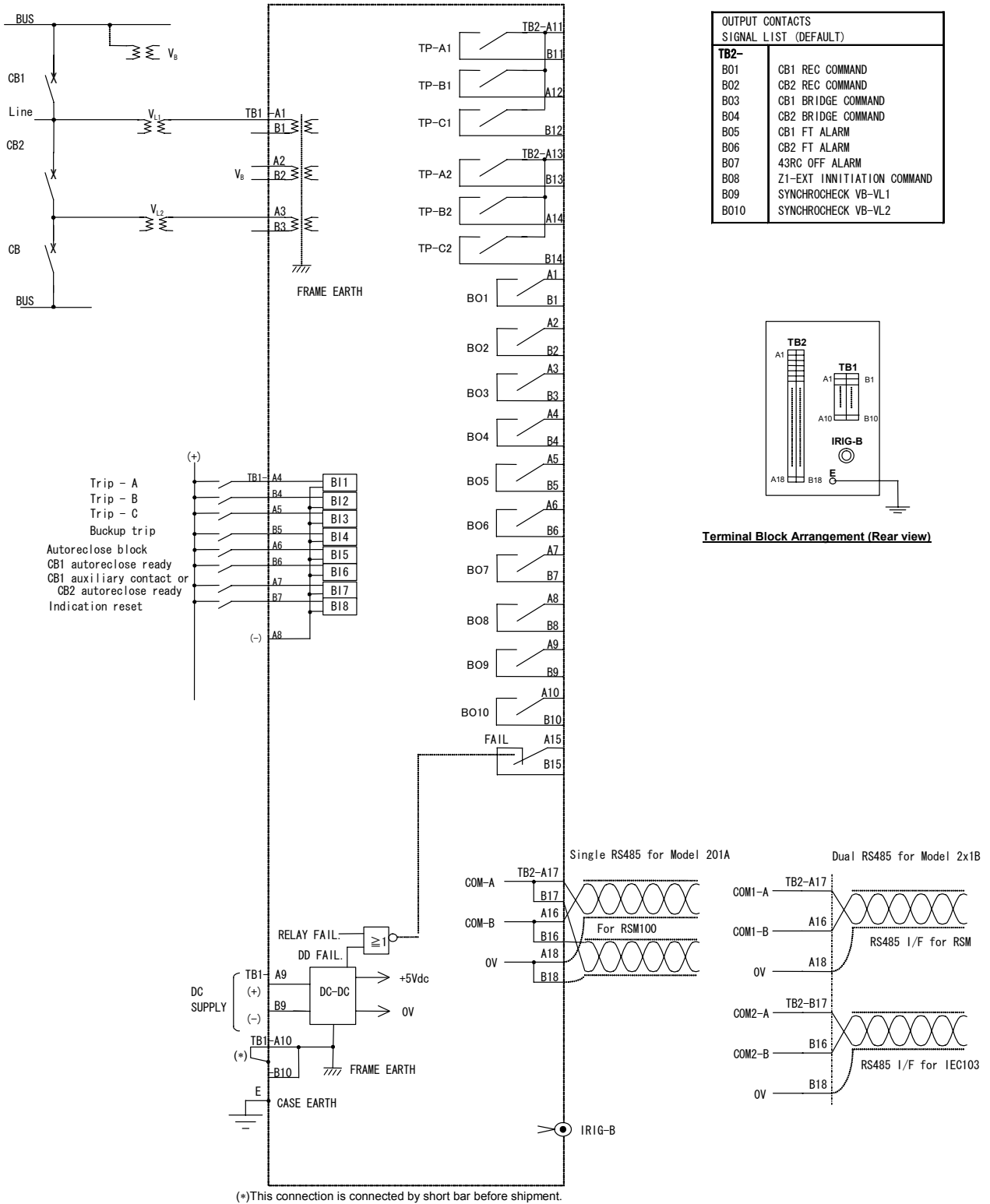

Figure 8. Typical External connection for Model 2x1

Numerical Relay
GPR100
AUTORECLOSING PROTECTION

TOSHIBA

TOSHIBA CORPORATION

Power Systems Company

1-1, SHIBAURA 1-CHOME, MINATO-KU, TOKYO 105-8001, JAPAN

PHONE; +81-3-3457-3644 FAX; +81-3-5444-9168

<http://www.toshiba-relays.com>

The data given in this catalog are subject to change without notice.

6638-2 0803T1